

Installation & Operating Manual

VF3000 Coal Stoker Boiler

HARMAN[™]
HOME HEATING

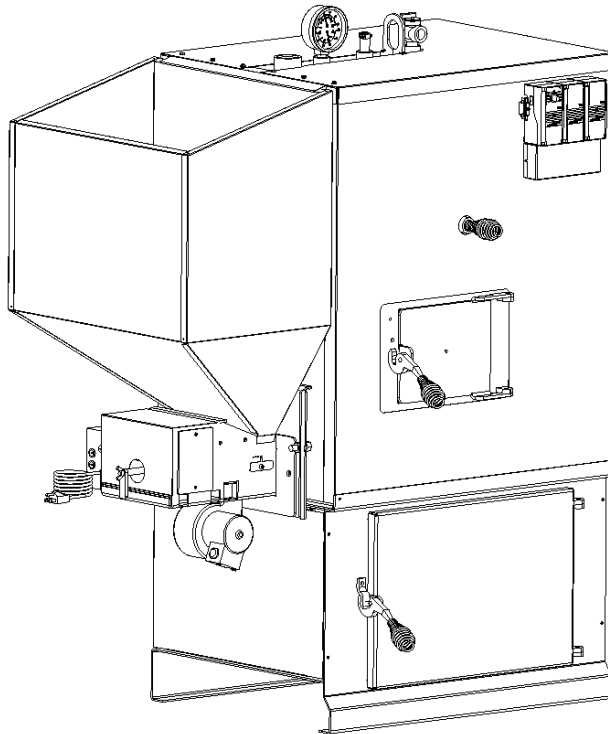

We suggest that our hearth products be installed and serviced by professionals who are certified in the U.S. by the National Fireplace Institute (NFI) as NFI Specialists.



Intertek R4

SAFETY NOTICE

PLEASE READ THIS ENTIRE MANUAL BEFORE YOU INSTALL AND USE YOUR NEW ROOM HEATER. FAILURE TO FOLLOW INSTRUCTIONS MAY RESULT IN PROPERTY DAMAGE, BODILY INJURY, OR EVEN DEATH.

FOR USE IN THE U.S. ONLY. NOT SUITABLE FOR INSTALLATION IN MOBILE HOMES

IF THIS BOILER IS NOT PROPERLY INSTALLED, A HOUSE FIRE MAY RESULT. FOR YOUR SAFETY, FOLLOW INSTALLATION DIRECTIONS. INSTALLATION SHOULD BE PERFORMED BY A QUALIFIED INSTALLER.

CONTACT LOCAL BUILDING OR FIRE OFFICIALS ABOUT RESTRICTIONS AND INSTALLATION INSPECTION REQUIREMENTS IN YOUR AREA.

CONTACT YOUR LOCAL AUTHORITY (SUCH AS MUNICIPAL BUILDING DEPARTMENT, FIRE DEPARTMENT, FIRE PREVENTION BUREAU, ETC.) TO DETERMINE THE NEED FOR A PERMIT.

THIS APPLIANCE IS ALSO APPROVED FOR INSTALLATION INTO A SHOP.

SAVE THESE INSTRUCTIONS.

3-90-70741

Introduction	4
Specifications	5
Hot Water Coil	5
Warnings	6
Packing List	7
Assembly	8
Venting	11
Installation	14
Verti-Flow™ Stoker Control	17
Operation	19
Feed Adjustment	19
Maintenance	20
Troubleshooting	22
Aquastat Installation	23
Feeder Parts List	25
Wiring Diagram	26
Service Parts	27
Warranty	29

Introduction

The VF 3000 Stoker Boiler features our patented Verti-Flow™ Coal Feeder. The VF 3000 has a 5,000 to 95,000 BTU range and 250 lb. coal hopper capacity.

An aquastat is used to activate the feeder when more heat is needed to maintain the set water temperature. When the Aquastat senses the water is at the set temperature the feeder stops feeding coal. Now the Verti-flow™ Stoker Control takes over to maintain a very low fire until more heat is needed.

Properly installed and maintained, your VF 3000 will heat your home for a lifetime. Therefore, have your unit professionally installed. Consult with your Harman Dealer regarding proper maintenance.

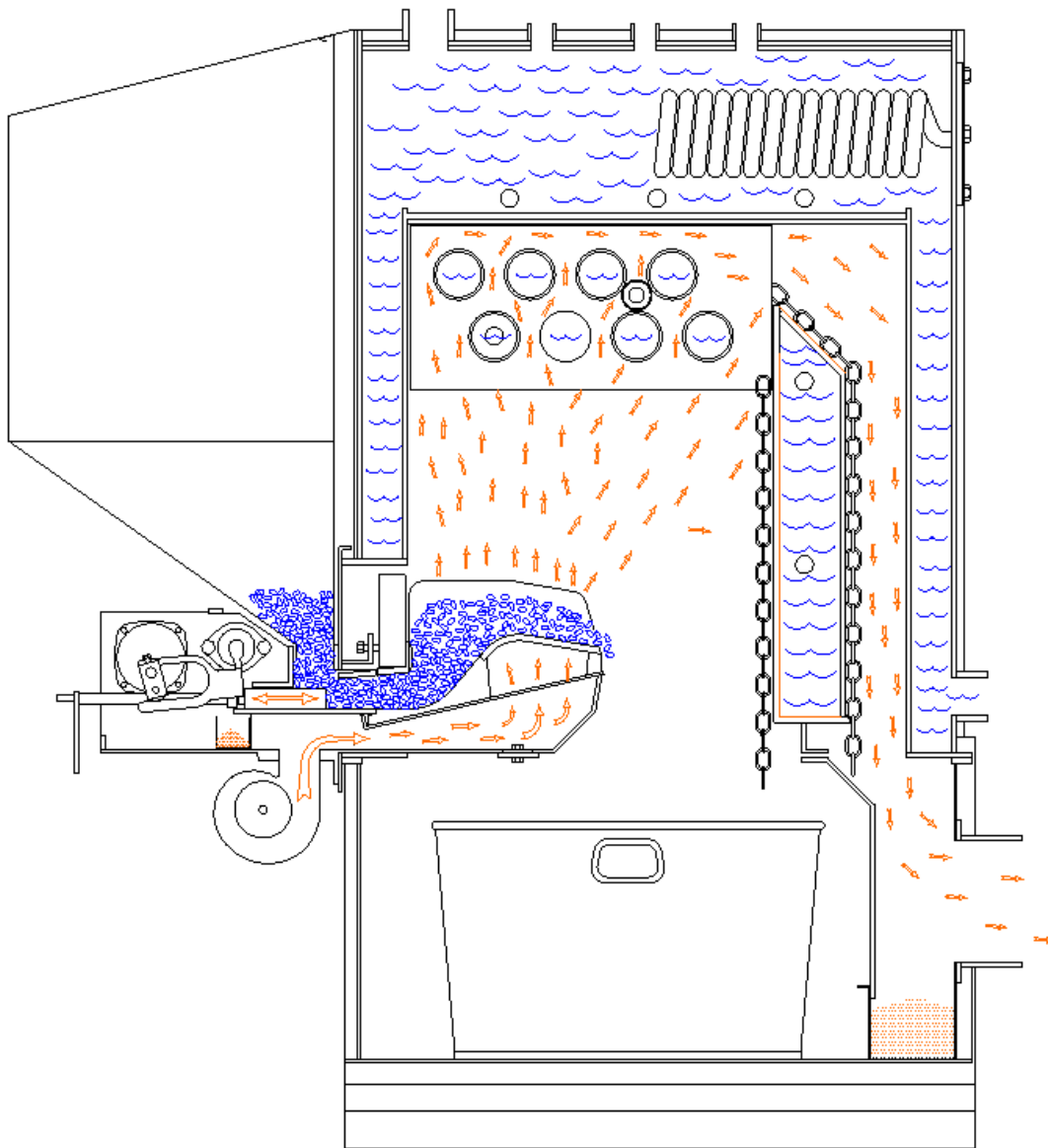

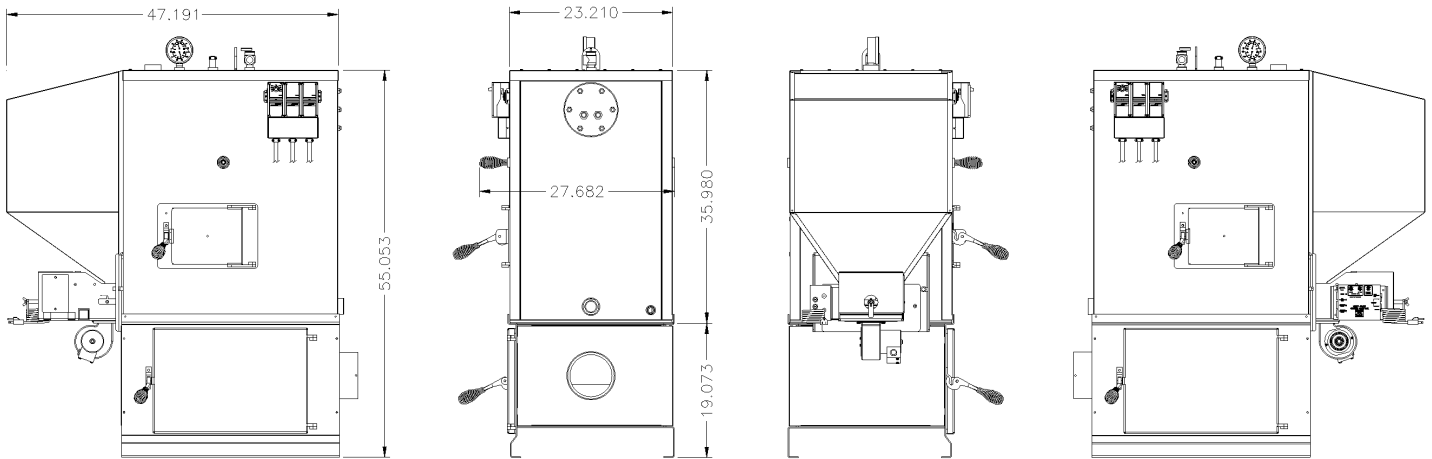

Hot Water Coil

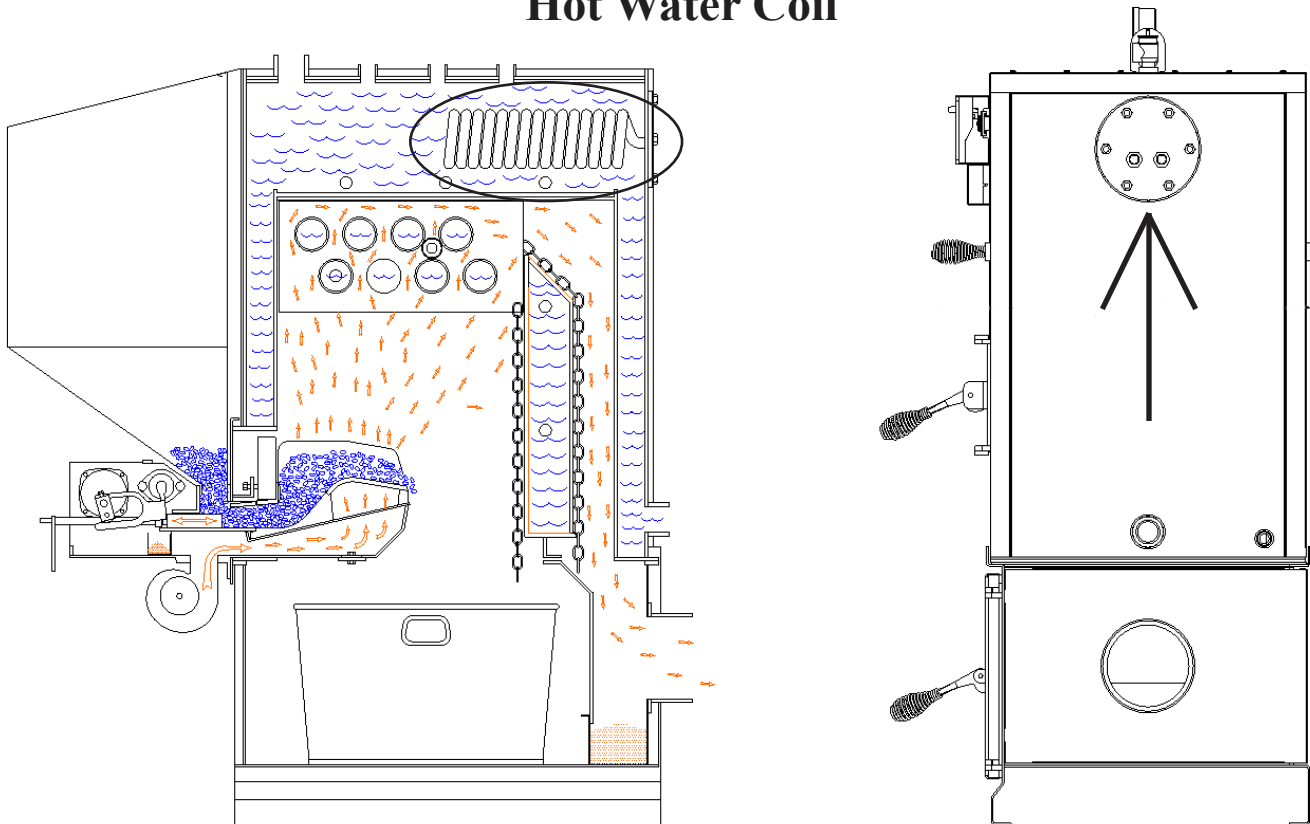

To install a hot water coil:

1. Remove the blank plate covering the water coil opening.
2. Insert the coil into the boiler as shown. Be sure to put a new gasket around the coil plate.
3. Tighten all bolts evenly.
4. Fill the boiler and check for leaks before and after the boiler is up to temperature. Rust caused by a leak can reduce the life of the boiler.
5. A tempering valve may be installed between the in and out pipes to reduce the maximum water temperature at the tap.

NOTE: This hot water coil is rated at 4 gallons per minute.

Warnings

Never sleep in the same room with any coal burning stove.

Always empty the hopper when not burning for more than a week. When left standing for long periods with wet coal, the pusher block will rust and corrode, causing it to seize. If the stoker is then turned “on”, damage to the pusher assembly and feed motor will result. This will be considered neglect and will void the warranty on those parts. Always check to see if moving parts are free before using if the unit has not been burned for a period of time. This can best be determined by shaking the adjuster rod.

Freshly delivered coal is typically watered down to minimize dust when loading and unloading. Wet rice coal does not flow as well as damp or dry coal, and may bind or bridge in the hopper. We do not recommend loading your hopper with wet coal. If you must burn wet coal, the feed rate will likely need increased, in order to get the same size fire. As the wet coal in the hopper dries out, the feed rate will need decreased to avoid over-feeding. Using wet coal, in an emergency, will likely not damage your stove as long as it is hot and burning at the time. The damage is caused when the hopper has wet coal in it when the stove is cold. This will cause rust and corrosion which is considered neglect and will not be covered by the product warranty.

Appliance Placement: The VF3000 must be installed on a non-combustible floor. The non-combustible floor must also extend a minimum of 18” in front of the firebox door, and 8” to the sides. Maintain a minimum of 18” of clearance to combustible walls, 24” to the ceiling and keep combustible materials a minimum of 36” away from in front of the appliance.

This boiler may be connected to an existing boiler heating system. Inter-connection may be done in a series or parallel configuration. Consult with your licensed plumber or HVAC professional to determine the most effective installation for your heating needs.

This unit must be connected to a chimney capable of providing a -.04 minimum draft. **WARNING:** If the chimney has no draft, coal gases may escape from the unit and stove pipe. These gases are toxic and can be fatal. It is recommended that a CO detector be installed to warn of this condition.

Parts inside feeder box

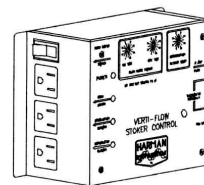
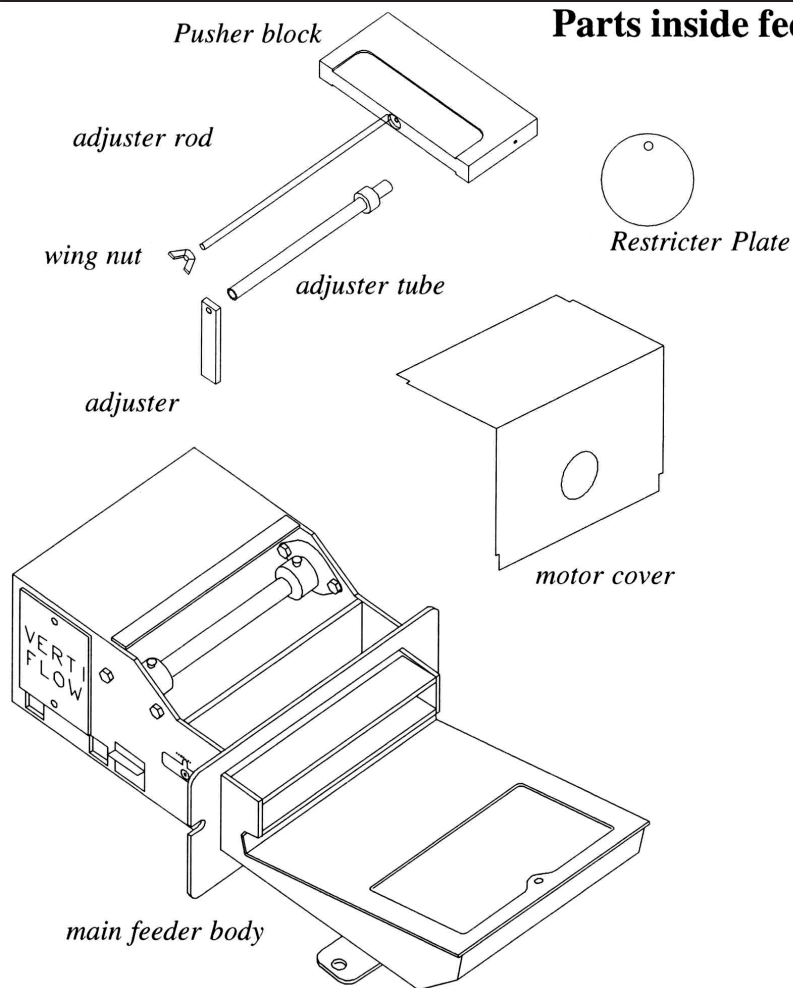

(2) Crimp-on terminals for Aqua Sensor
(4) #8-32 X 1/2" screws and nuts to mount the timer control box.

NOTE: Although required for unit completion, the Feeder and Hopper are sold as separate items.

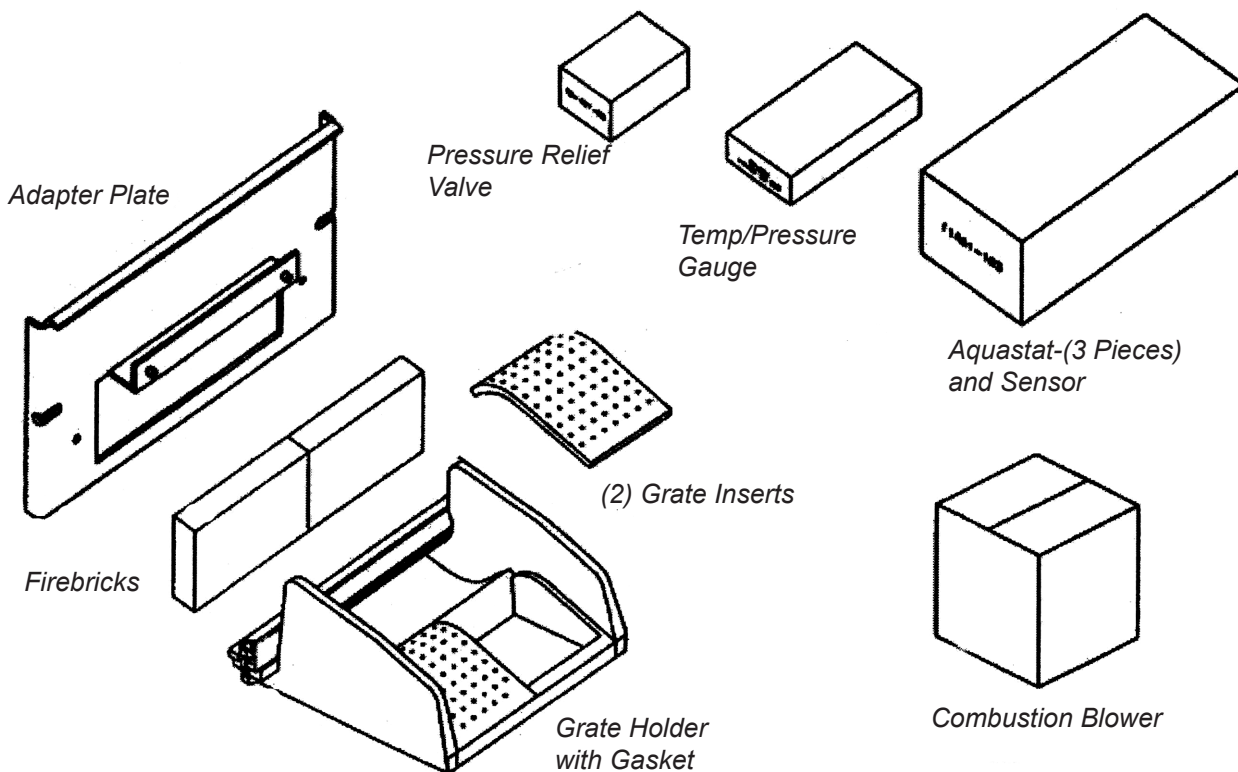

Assembly

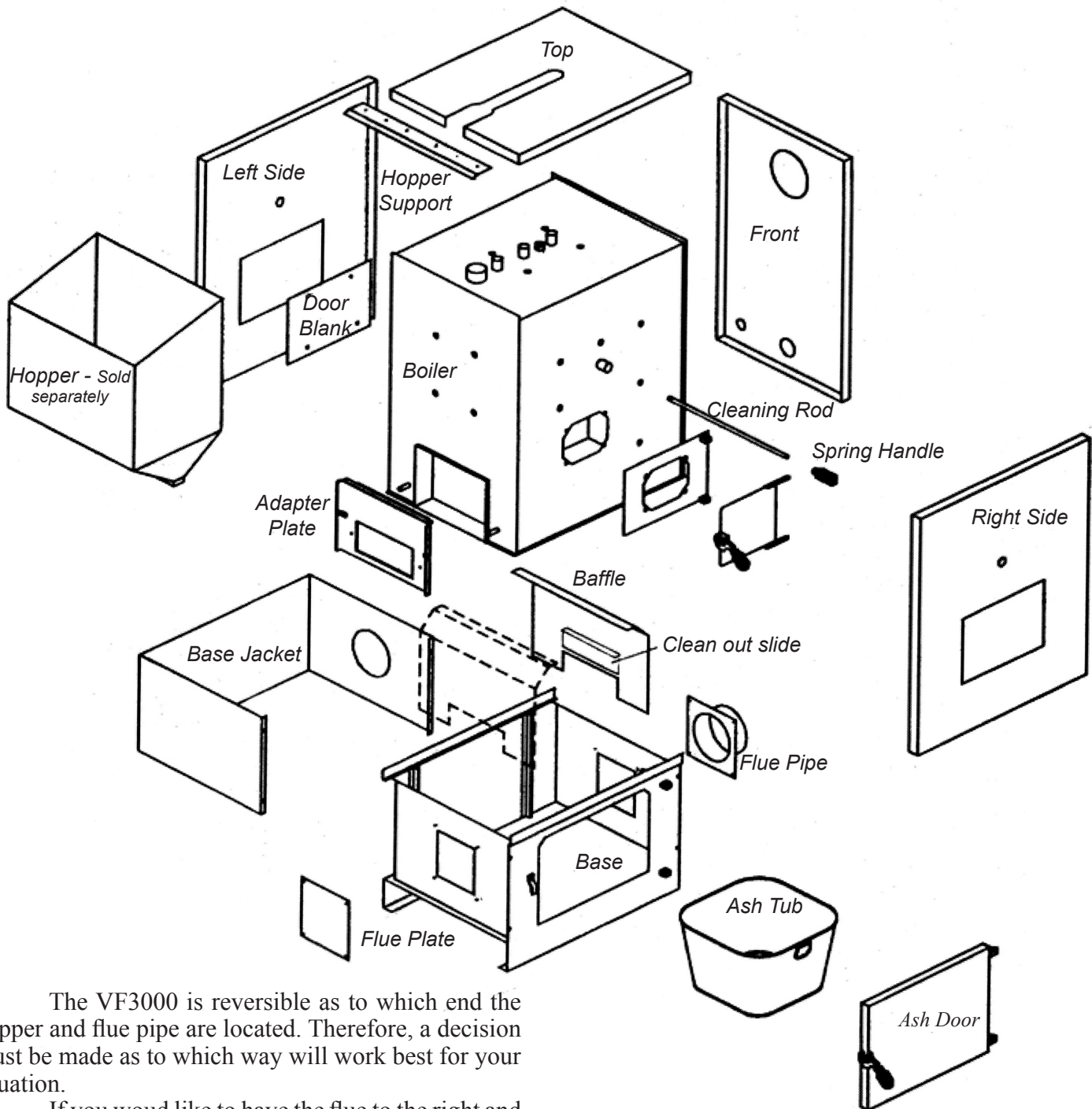

The VF3000 is reversible as to which end the hopper and flue pipe are located. Therefore, a decision must be made as to which way will work best for your situation.

If you would like to have the flue to the right and the hopper to the left, make sure the gaskets are in place on both the flue pipe and flue plate. Bolt the flue pipe on the right end and the flue plate on the left end of the base. Next, the baffle must be slid into place on the right end with the center of the base. Note the baffle and flue pipe must always be at the same end and opposite the hopper.

Next, place the base jacket around the base and clamp into place with the four clamping bolts on the front of the base. The hole in the jacket goes around the flue pipe.

Place 1/4" x 1" gasket around the flat edge on top of the base. Now place the boiler on top of the base with the feeder opening opposite the flue pipe. Place 1/4" x 1" gasket around the door openings on the boiler. Bolt the door mount on the front door opening with 5/16" x 1" flat head bolts. Bolt the door blank on the rear opening with 5/16" x 1" hex head bolts.

Now the outer jacket can be installed. The front jacket with the coil hole must be installed first. Next, the two sides which hold the front in place and then the top which holds the sides in place.

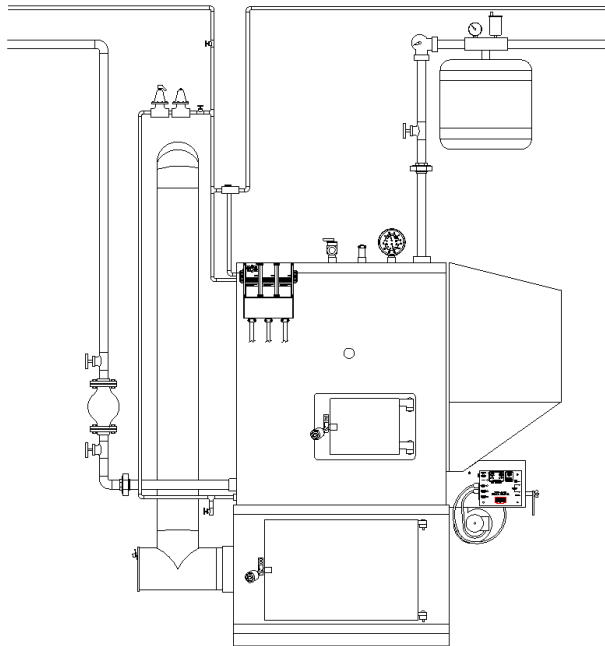

Hopper right, flue left

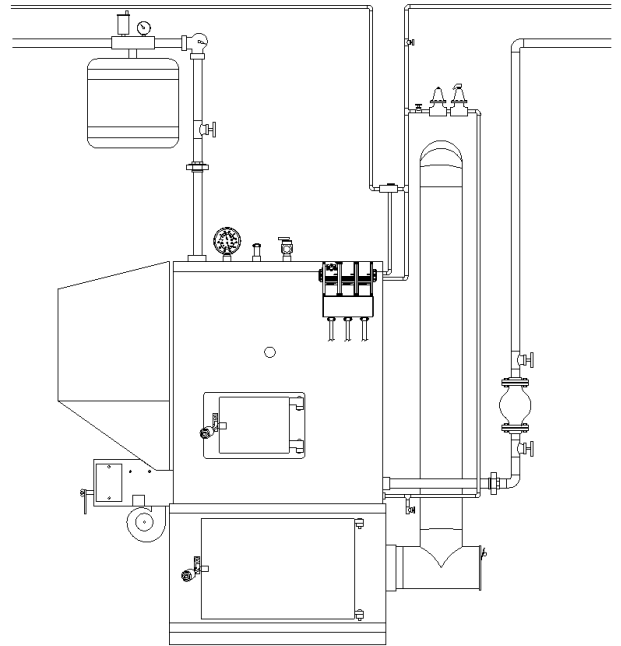

Hopper left, flue right

Feeder

Begin assembly by sliding the pusher block with the adjuster rod from the front through the slot shown in Fig. 1. Be sure the pusher block is turned with the bolt hole to feed indicator side. Next, hold pusher block in the most rearward position and slide the adjuster tube over the adjuster rod until it bottoms out on the pusher block. Thread the adjuster, then the wing nut on the end of the adjuster rod.

Put gasket around the opening on the adapter plate. Slide the feeder through the plate and bolt together with two 5/16 x 3/4" bolts. Next, install the grate holder.

Grate

The grate is composed of four pieces: the grate holder, (2) grate inserts, and firebrick angle. The firebrick angle is bolted to the grate holder with (2) 3/8" x 1 1/4" bolts. Before installing the grate holder, 3/8" round gasket must be checked in the groove on the bottom side of the grate holder, as shown in fig. 4. Check to be sure the gasket has not been damaged. Locate the flange at the rear of the grate holder into the slot on the feeder as shown at left. Bolt the front end down snug with the 1/4" x 20 allen bolt and nut provided. The rear end will be locked in place by the flange.

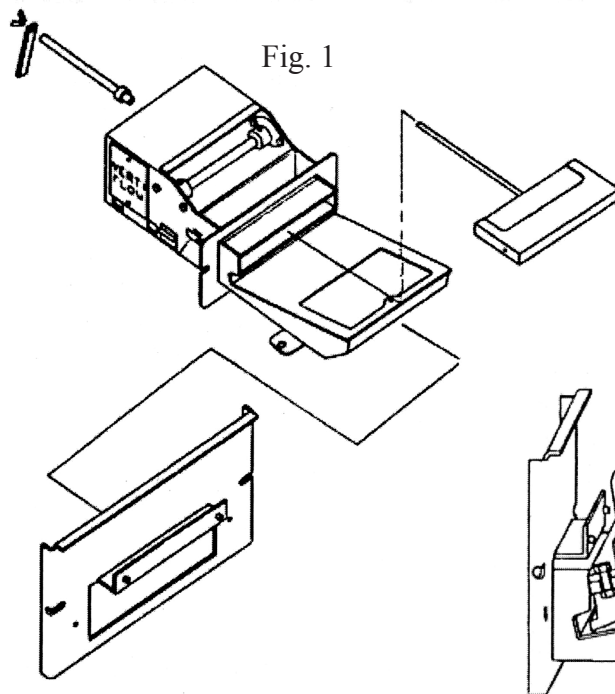

Fig. 1

Fig. 2

Before completely tightening the bolt, be sure the grate holder is back as far as possible and centered side to side on the feeder opening.

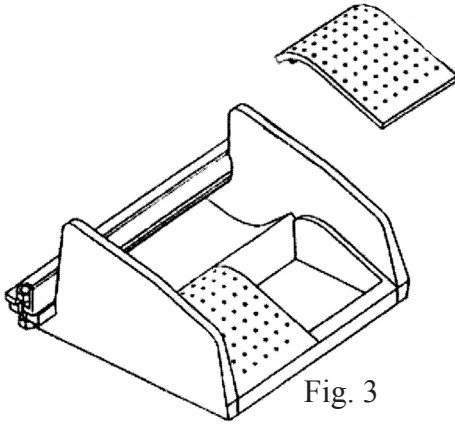

Fig. 3

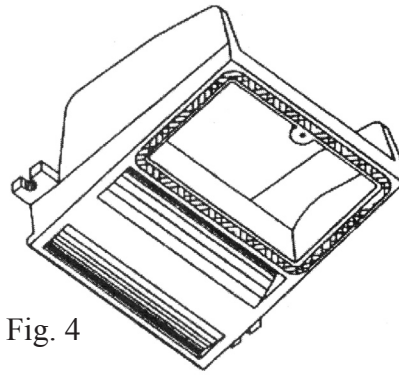
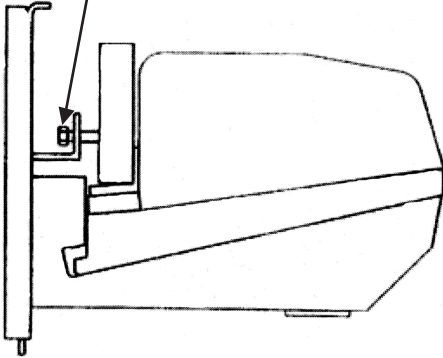

Fig. 4

Snug these bolts only.



Grates and Firebrick

Lay the two grate inserts into the grate holder as shown. Divide the spaces between the grates equally and be sure they are not tight. The spaces are needed for expansion. The grate inserts can also be installed or removed after the feeder is in place.

Place the two firebricks on the grate angle and make the two bolts snug on the adapter plate as shown.

Apply 1 inch flat gasket around the feeder opening and insert the feeder and adapter plate into the boiler and tighten. NOTE: You will need a 3/4" socket to do this.

Blower

Remove one of the screws on the intake screen, and install the blower restrictor plate. Install the blower on the bottom of the feeder by sliding it into the bracket as far as it will go. NOTE: The bolt holes on the blower flange are not used.

Control Box

Install the control box on mounting pad provided on the side of the stoker with (4) #8-32 bolts and nuts.

Plug the gear motor into the top receptacle, and the combustion blower into the middle receptacle on the control box. The bottom receptacle is not used.

Hopper

Insert small end of hopper into the hopper slot on the feeder. Push top of hopper under the hopper support, causing the slot on the bottom side of the support to hook onto the hopper. The hopper support will spring up slightly for the hopper to go under. If you have difficulty getting the hopper under, you can raise the top slightly.

The feed motor cover can now be installed.

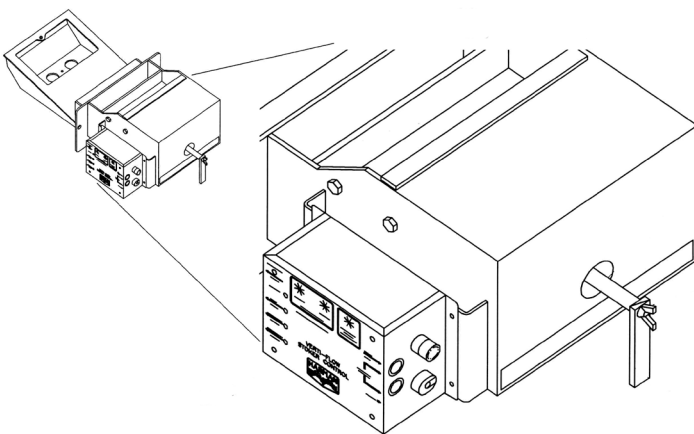

Chimney Connectors and Chimneys

Draft

Draft is widely misunderstood. It is important that you, the stove operator, realize that draft is a variable *effect*, not a given quantity. Stoves and chimneys do not *have* draft, yet draft is the key to your stove's performance.

Draft is a force, produced by an operating stove and the chimney to which it is attached. It is created by hot gases rising up the chimney, creating a pressure difference between the inside of your home and the outside air. It continually moves fresh combustion air into the stove, and hot exhaust gases out of the stove; without this constant flow, the fire will go out.

Other factors, such as barometric pressure, winds, the tightness of the home, the total inside chimney volume, chimney height and the presence of venting devices such as exhaust fans also play a role in maintaining an adequate draft. Low barometric pressures, super insulated homes, and exhaust fans can reduce draft; winds can play havoc with draft; and too large or too small a chimney volume can cause reduced draft due to the excessive cooling or not enough room to vent the exhaust gases. Introducing outside air directly to the stove may help remedy a low draft problem. Some signs of inadequate draft are smoking, odor, difficulty in maintaining the fire, and low heat output. Overdraft can be caused by a very tall chimney even if it is the recommended size, and can cause overfiring of your stove. Signs of an overdraft include rapid fuel consumption, inability to slow the fire, and parts of the stove or chimney connector glowing red. It is important that you follow the chimney guidelines in this manual, including size, type, and height to avoid draft problems.

When installed and operated according to this manual, the appliance will produce enough hot gases to keep the chimney warm so that adequate draft is maintained throughout the burn cycle.

Chimney Connectors

In general, following these guidelines will ensure compliance with all national and provincial codes; prior to beginning your installation, check with your local building code official(s) regarding any additional local requirements or regulations which may influence the design and placement of your venting system.

The VF3000 may be installed with (.6 mm) 24 gauge chimney connector pipe. The size of the connector should correspond to the size of the flue collar opening. Do not use makeshift components.

No part of the chimney connector may pass through an attic or roof space, closet or other concealed space, or through a floor or ceiling. Whenever possible, avoid passing the connector through a combustible wall; if you must, use an approved wall pass-through, described later in this section.

Assemble the connector beginning at the flue collar, with the crimped ends pointing towards the stove (to keep debris and creosote flakes inside the system). Each joint, including the one to the stove's flue collar and the one to the chimney itself should be secured with at least three sheet metal screws. Screws may be a maximum of 3 inches apart. A 1-1/4" (32 mm) overlap is required at each joint, including the flue collar attachment. No more than two 90 degree elbows should be used, and the total length of connector should not exceed 10 feet (3m) All horizontal runs of connector must have a minimum upward slope of 1/4" per foot (20 mm per meter).

Wall Pass-thrus

Occasionally it is necessary to pass the chimney connector through a combustible wall to reach the chimney. Depending on your local building codes, and the pertinent provincial or national codes, there are several choices for accomplishing this safely. Before beginning your installation, contact local officials, and also the chimney connector and chimney manufacturer for specific requirements.

Canada. Three methods are approved by the Canadian Standards Association. The diagram shows one method requiring an 18" (460 mm) air space between the connector and the wall. It allows use of one or two covers as described in the diagram. The other two methods are described in detail in the current issue of CAN/CSA B365, the national standard.

United States In the U.S., the national code is NFPA 211. While many localities adopt this standard, be sure to check with local authorities before beginning your installation.

The NFPA (National Fire Protection Association) permits four methods for passing through a combustible wall. A commonly used method to pass through a wall directly to a masonry chimney is to clear a minimum 12"(305 mm) around the entire chimney connector, and fill it with brick masonry which is at least 3.5"(90 mm) thick. A fireclay liner, minimum 3/8" (9 mm) wall thickness must run through the brick wall to the chimney liner (but not beyond the inner surface of the liner). It must be cemented in place with refractory cement. This method is illustrated. For details on the other three options, refer to the most recent edition of the NFPA 211 code.

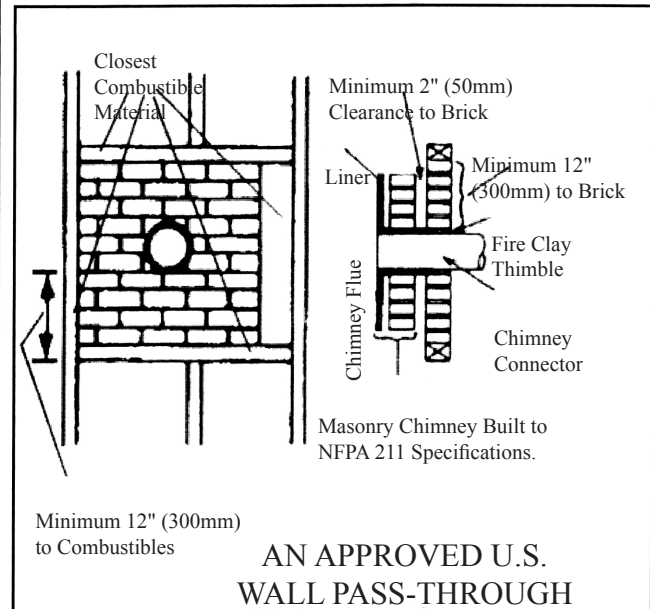
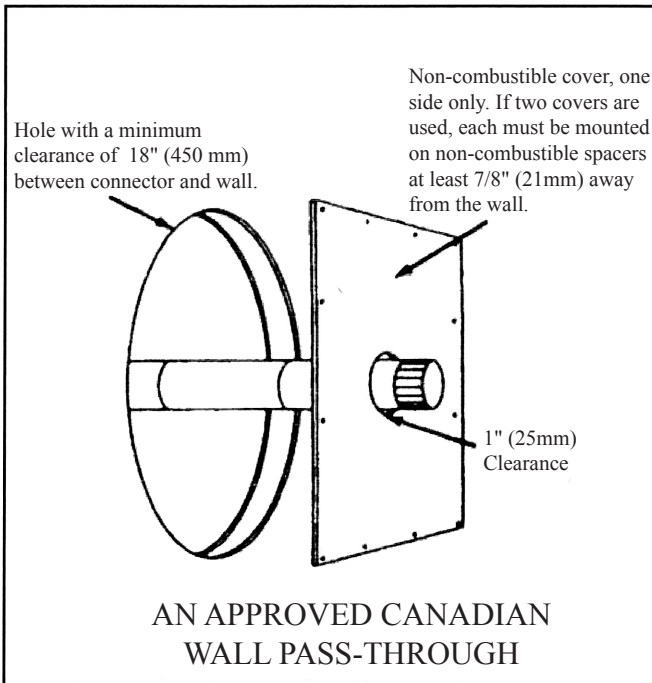

The Chimney

This unit must be installed into a chimney approved for use with solid-fuel appliances. In the U.S., it must be connected to (1) a prefabricated chimney complying with the requirements for Type HT chimneys in the Standard for Chimneys, Factory-Built, Residential Type and Building Heating Appliances, UL 103, or (2) a code-approved masonry chimney with a flue liner.

In Canada, this unit is listed for use with prefabricated chimneys tested and listed to the high temperature (650 degrees C) chimney standard, ULC S-629, or with a code approved masonry chimney.

The minimum recommended height for any chimney is 16 ft (4.8 m) above flue collar height. A round flue (either masonry or approved prefabricated), of either 6" (150 mm), 7" (180 mm) or 8" (200 mm) may be used. For square or rectangular masonry chimneys, nominal sizes of 8" x 8" or 8" x 12" (200mm x 200 mm, 200 mm x 300 mm) may be used.

Codes require that solid-fuel chimneys extend 3 ft (0.9 m) above the highest point at which they exit from the roof. Then, the chimney must extend 2 ft (0.6 m) above the highest point within a 10 ft (3 m) radius. Thus, the 3 foot, 2 foot, 10 foot rule:

- 3ft.** - Above roof exit point
- 2ft.** - Higher than anything within-
- 10ft.** of the chimney.

Do not connect this unit to a chimney flue servicing another appliance.

This VF3000 Is Approved To Burn Anthracite "Rice" Coal Only.

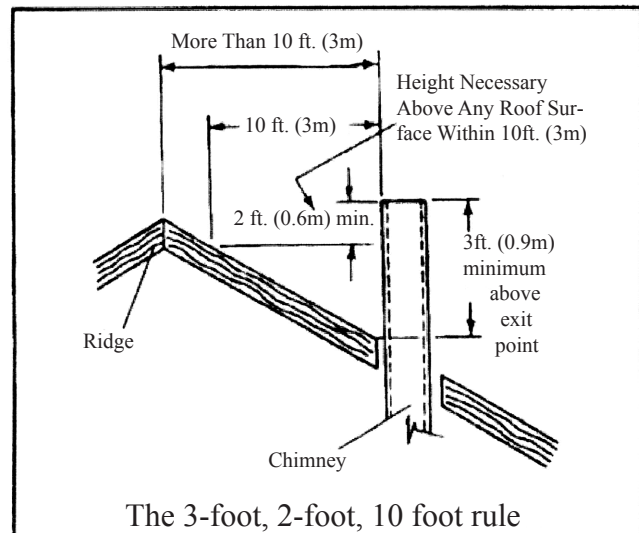

Existing Masonry Chimneys

If you plan on using a pre-existing masonry chimney, have it thoroughly inspected and cleaned. Any faults which make the chimney unsafe and unusable must be repaired prior to use. These can include improper height, structural defects, blockages, inadequate clearance to combustibles, unsealed openings into other rooms of the house, signs of creosote or smoke leakage, a loose or absent clean-out door, or absence of a liner.

Do not connect to any air distribution duct or system

Venting to a Masonry Chimney

When connecting to a masonry chimney, several provisions are standard. First, whether the chimney connector is vented to the chimney through a thimble or a breech pipe, neither must pass beyond the inner surface of the chimney liner, and both must be firmly cemented in place with refractory cement. (A thimble is a masonry pipe which is inserted through the chimney wall, and is frequently the preferred method; a breech pipe is a piece of steel pipe used the same way.) In Canada, a breech pipe has ridges or protrusions to lock it firmly into the refractory cement. In either case, the chimney connector vents to the chimney through the thimble or breech pipe.

Using a thimble, the connector slides completely inside the masonry to the inner edge of the flue liner, and may be easily removed for chimney and connector inspection. A breech pipe must extend at least 2" (50 mm) into the room, so the connector can be attached with sheetmetal screws.

Venting to a Masonry Fireplace Chimney

In some situations, a code compliant chimney originally used for a masonry fireplace may be used to install your stove. In addition to the requirements found in the previous paragraphs, it is important to be aware that all clearances must be met, including those from the chimney connector to combustibles. Do not forget to include floor protection in your plans. (See Clearances and Floor Protection in this section.) Since many fireplaces have exposed wooden mantels and trim, pay special attention to the clearances necessary to these materials.

If your fireplace chimney is behind a combustible wall, you must use an approved wall pass-through system to gain access to the masonry chimney. The chimney connector must enter the chimney at a place where it is lined, and the fireplace must be made inoperable. For example, you might remove the damper, replacing it with a secure, airtight, noncombustible seal (removable for inspection); this also satisfies the requirement that no room air must be allowed to enter the chimney.

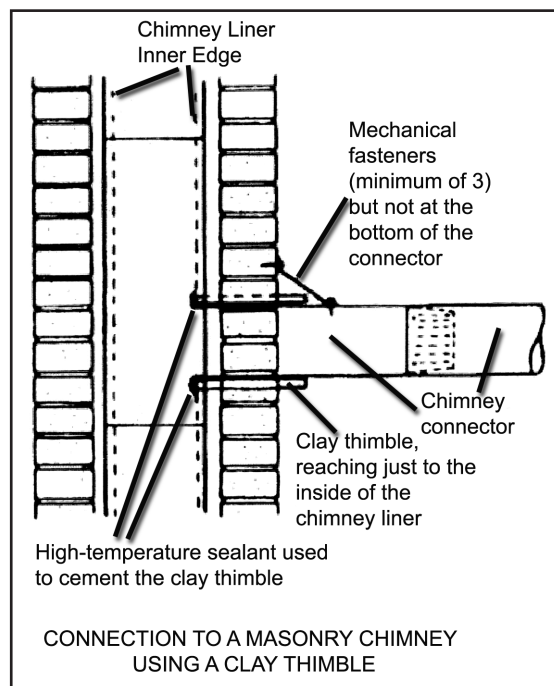

Do not burn any fuel other than coal. Never use highly volatile substances in your stove, such as gasoline, which could cause an explosion.

When solid fuels are burned completely, they produce water and carbon dioxide. However, in long slow burns, a substantial amount of carbon monoxide may be produced. If allowed to build up, carbon monoxide (which is odorless) can prove fatally poisonous. Proper ventilation and draft will prevent this from happening. If you smell smoke, thoroughly ventilate your dwelling. Contact your dealer to arrange for a draft test.

Other causes of poor ventilation or draft are icing, exhaust fans, a blocked outside air inlet, and room air starvation. If your stove is sluggish and you get occasional odor, check these possibilities and increase the air flow in your home.

Installing to a Prefabricated Chimney

When venting your stove using a prefabricated chimney, be sure to contact local building code authorities, and to follow the manufacturer's instructions *exactly*. Use only the manufacturer's parts; do not use makeshift installation techniques. All prefabricated chimneys must be tested to either the U.S. or Canadian high-temperature standards, UL 103 or ULC S629.

Aquastat and Wiring

See page 23 for assembly and mounting details. Pay close attention to the jumper positioning inside the A350 and S350 controls. Also note the sensor and its wire length when considering the mounting location. Remember that 212° f. is boiling temperature and must be avoided. Be sure to incorporate a means for flowing water in the event of an over-heat condition. Coal can not just stop burning when there is no demand for heat. Never fire a boiler with no water in the system. Serious consequences will result.

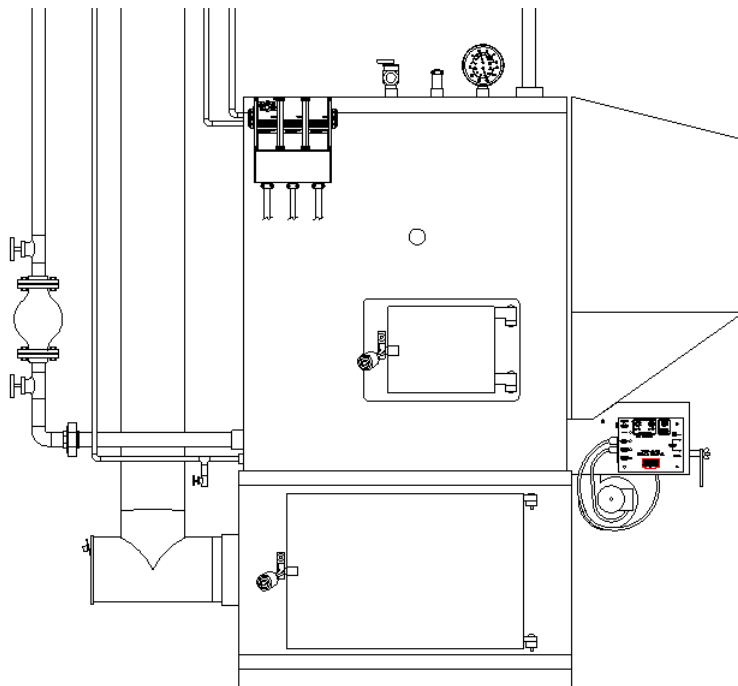
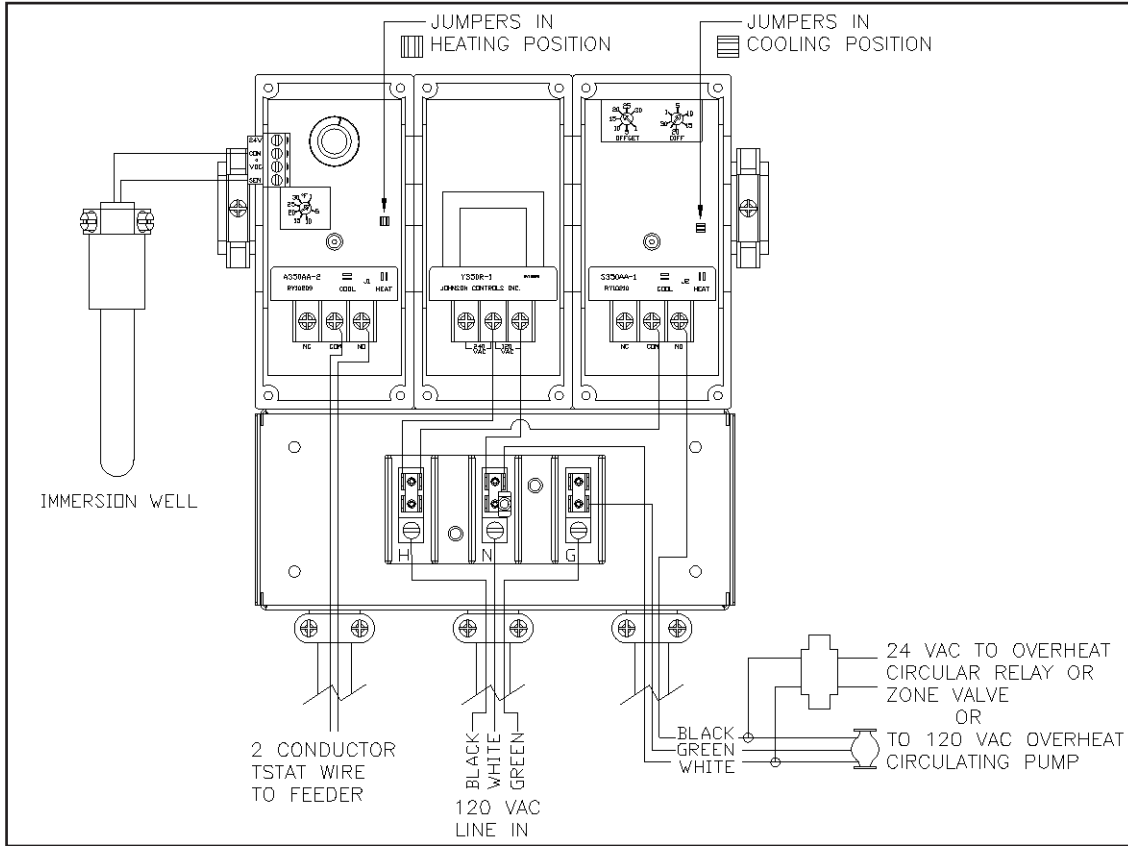

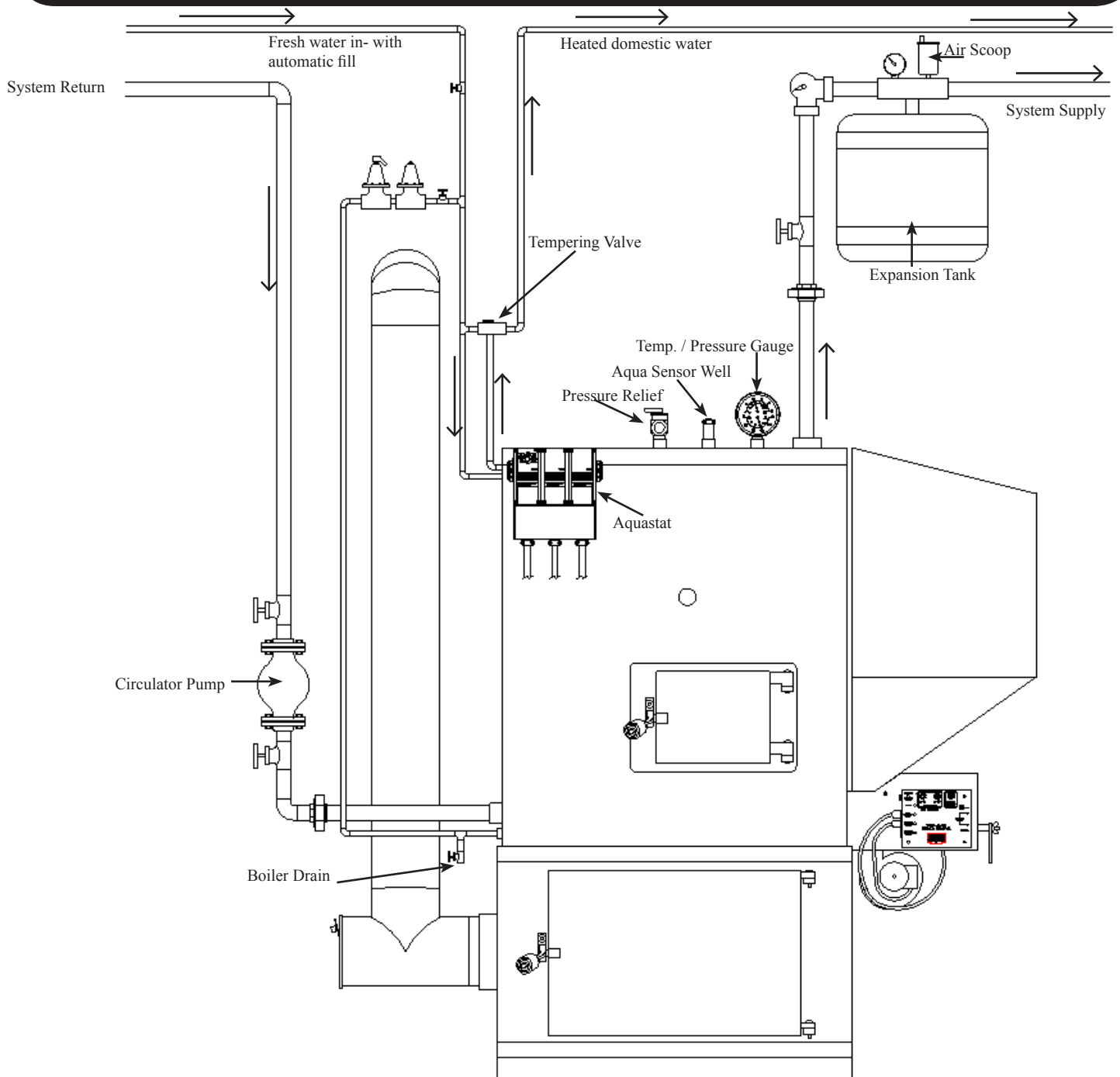

Basic Plumbing

This is a basic plumbing hook up. Your system may vary depending on many factors. Therefore, we recommend having experienced personnel do the plumbing.

This is only one of many layouts possible. Circulator pumps, zone valves, and thermostats are not supplied with the unit because the amount and type of these parts vary with every system. It is best to have a professional plumber do the job.

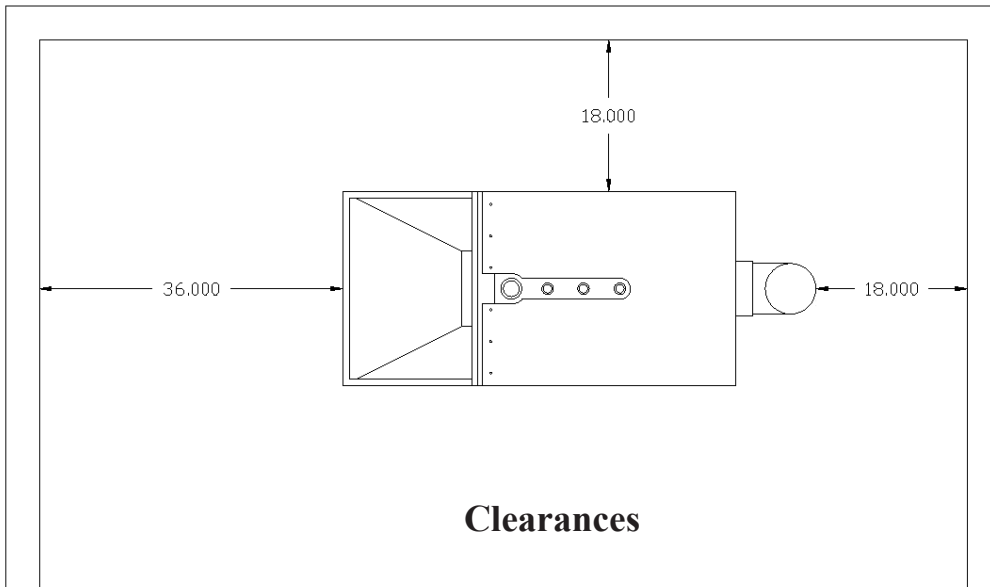

Installation

Place the boiler a minimum of 18" from a wall. The flue pipe must be at least 18" from anything combustible. The rear of the hopper should be a minimum of 36" from the wall. The boiler should be placed on a non-combustible floor. Secure all chimney connector pipe joints with a minimum of 3 sheet metal screws.

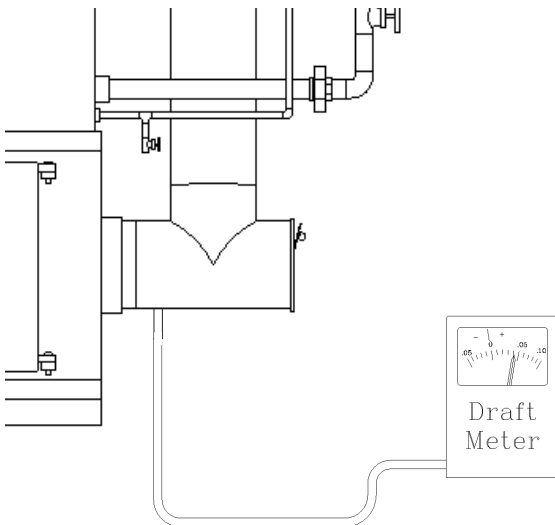

Draft Test Procedure

Attach a draft meter to the vent pipe on the boiler side of the barometric damper (if installed). With a fire established, the chimney draft should be between $-.04$ and $-.06$ inches of Water Column. If the flue draft exceeds these readings, install and adjust the barometric damper accordingly. DO NOT operate if the flue draft exceeds $-.10$ inches Water Column (-24.9 Pa).

Next, remove the allen head set screw from the center of the firebox door and attach your draft meter. The firebox draft should be $-.04$ to $-.05$ in W.C. Adjust the combustion blower restrictor plate, closed to increase the draft or open to decrease firebox draft.

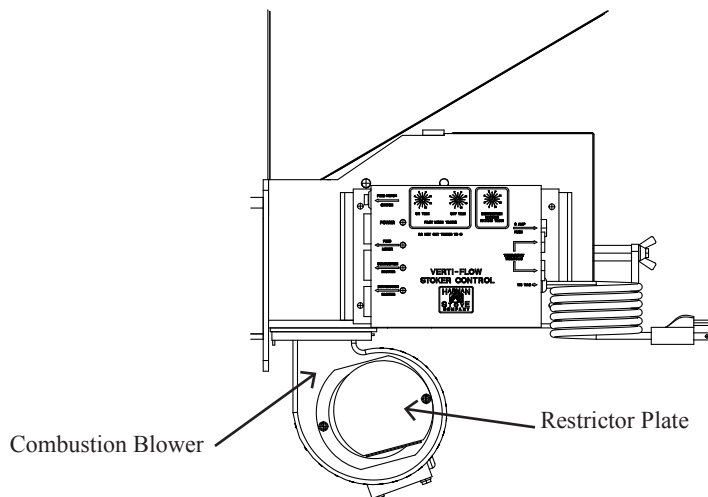

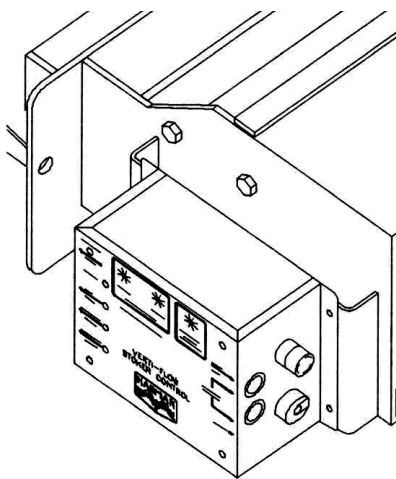
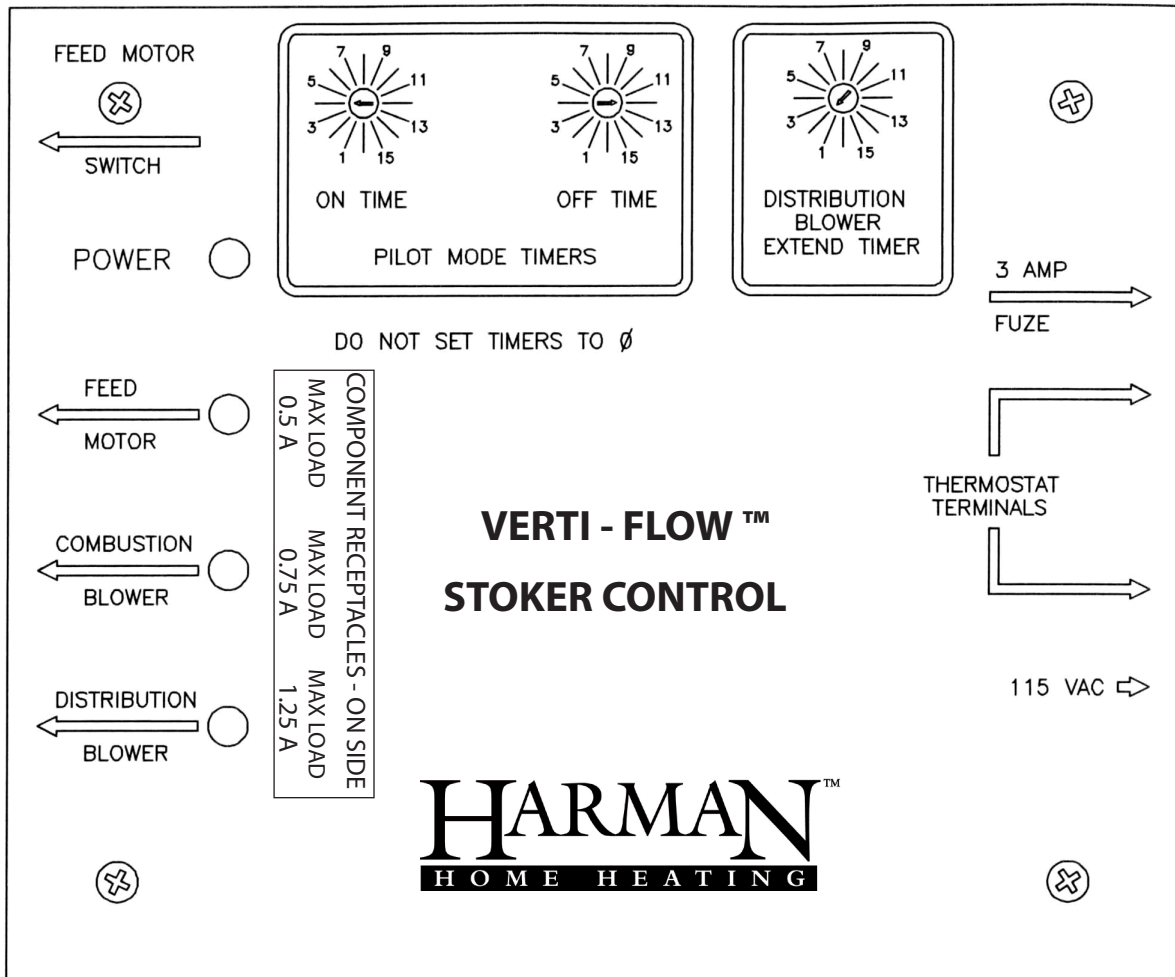

Verti-Flow™ Stoker Control

This section describes the features and operations of the Harman Verti-Flow™ Stoker Control. The timers are adjustable from 0 minutes to 15 minutes in 1 minute steps. There are red lights on the front panel to show proper operation of the timer. One indicator shows power is applied to the unit. The other three indicators show when power is available at the adjacent receptacle.

The stoker control will be mounted on the side panel of the feeder directly below the coal hopper. The three receptacles and switch will be facing forward while the power cord, 3 AMP fuse access port and the thermostat connections will be to the rear.

The Verti-Flow™ Stoker Control

The top receptacle (0.5 A) provides power to the coal feeder motor. Thus, the plug from the coal feeder motor should be inserted into this receptacle.

The center receptacle (0.75 A) provides power for the combustion blower motor. Thus, the plug from the combustion blower should be inserted into this receptacle. The bottom receptacle (1.25 A) is not used.

The thermostat connections on the back panel of the stoker control are .25 inch male quick connect terminals. The mating connectors (supplied) should be .25 inch female quick connector terminals. The wire should be no smaller than 22 gauge.

The thermostat connections should be connected to the aquastat as shown on the wiring diagram.

The AC power cord should be the last connection made. The power cord should be plugged into a 115 VAC / 60 hertz wall outlet, which has proper grounding available. This 115 AC volt wall outlet should also be capable of handling 3 amps of current because this is the maximum amperage this unit will draw.

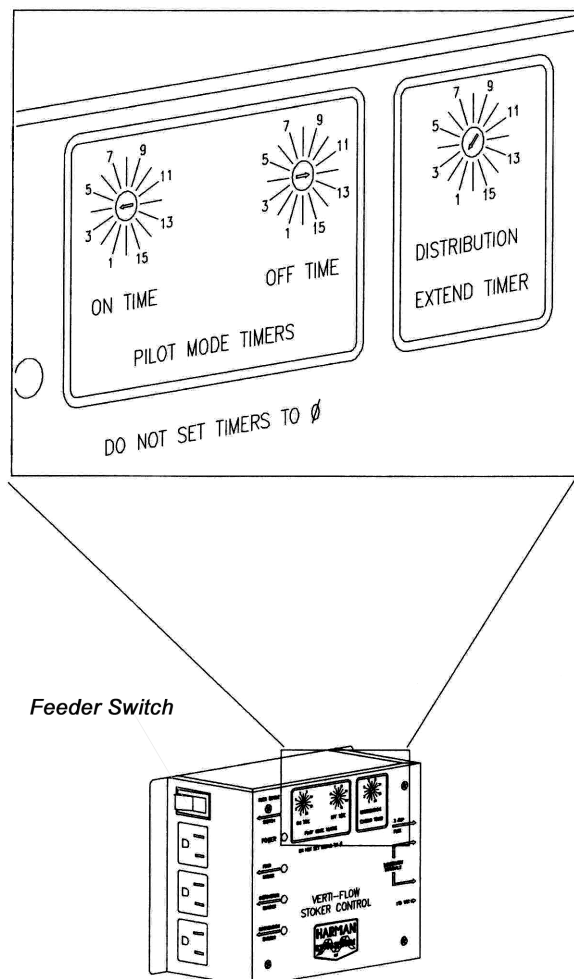

How to operate the Stoker Control

There are four operator interfaces on the Stoker Control. The operator interfaces are: one (1) rocker switch and three (3) 16-position rotary switches.

The rocker switch is a power switch that controls only the coal feeder motor. For normal operation this switch should be placed in the “on” position. This switch’s operation can be verified by a small red light above the coal feeder receptacle being on when the switch is on. The off position is used for lighting the fire.

The other three switches are the customer’s adjustments for the timers (on timer, off time, distribution blower time). These switches can adjust each timer individually from 1 minute to 15 minutes in 1 minute increments. Do not set pilot mode timers to 0.

The “on” time and the “off” time should be programmed to a minimum time that keeps the coal burning during the maintenance cycling mode. The distribution blower time should be set to 0. This is because the VF 3000 doesn’t have a distribution blower. The Verti-Flow™ Stoker Control is also used on the Magnum Stoker which does use this timer.

Recommended timer settings to start are: “on” 4 minutes, “off” 12 minutes, extend timer 0 minutes. You may find that these settings produce too much heat in pilot mode. If so, you can reduce the “on” time and increase the “off” time. However, we do not recommend going below 4 minutes with the on time for efficiency reasons.

Do not connect this unit to a chimney flue servicing another appliance.

DANGER- Risk of Fire or Explosion;
DO NOT burn garbage, gasoline, drain oil or other flammable liquids.

CAUTION- Hot While in Operation;
- Keep Children Away
- Do Not Touch

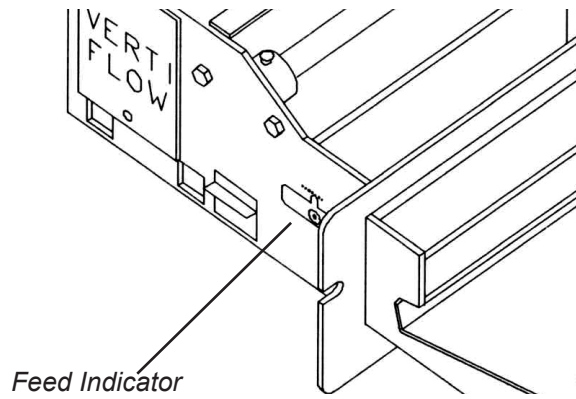

FILL THE BOILER AND PLUMBING SYSTEM WITH WATER PRIOR TO LIGHTING!

Starting a fire

Fill the hopper with rice coal. With the aquastat calling for heat, the coal will begin to feed onto the grate inside the stove. This process can be accelerated by adjusting the feed rate to the maximum position. When the coal starts to come up out of the grate and is almost up to the area where the holes start, turn the feed adjuster back about 2 turns and turn off the feed motor with the switch on the side of the control box. Whether using wood pellets, charcoal, or kindling and paper, mix your starter material with the coal on the grates, for best results. Use a match to light the fire or starting material.

After the coal is burning, the feed motor can be turned on and the coal fire will continue to get larger. Fresh coal will continue to be pushed onto the grate and ashes will be pushed off the grate. The feed rate must be adjusted so the coal is burned up and turned to ashes before the coal gets to within one inch of the end of the grate. Too high of a feed rate will push unburned coal off the coal grate, therefore wasting fuel.

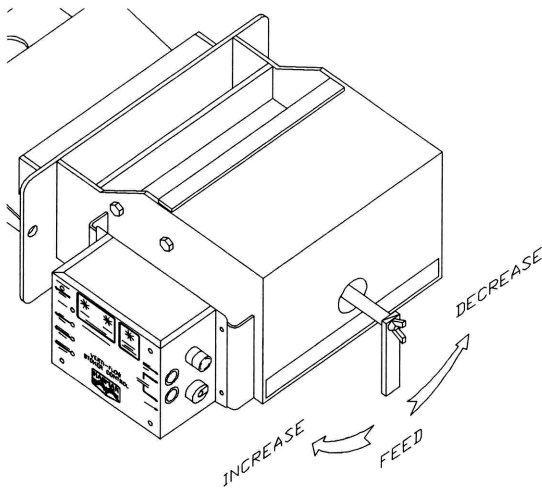

Feed Adjustment

The feed indicator on the side of the feeder shows how far the pusher moves each stroke. There are dots above the indicator spaced 1/8" apart. A movement of one dot would give a low burn, two dots medium and three dots high. Lock the adjuster with the wing nut after adjusting feed rate.

After the fire is burning and the feed rate is adjusted, you can now set the aquastat to the desired water temperature.

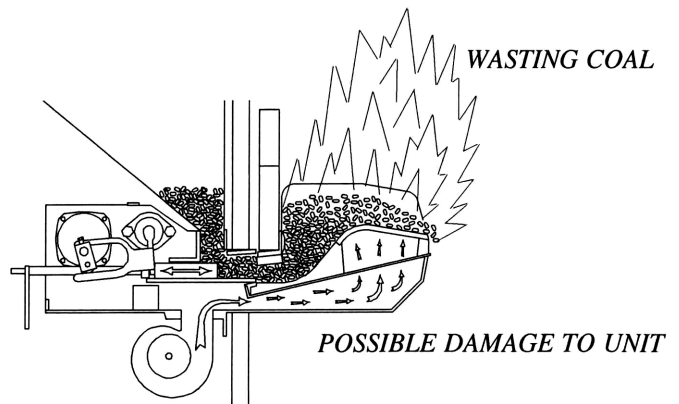
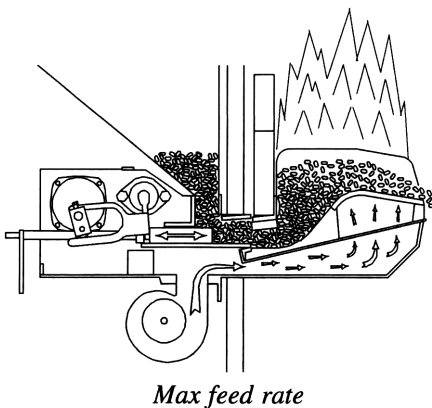
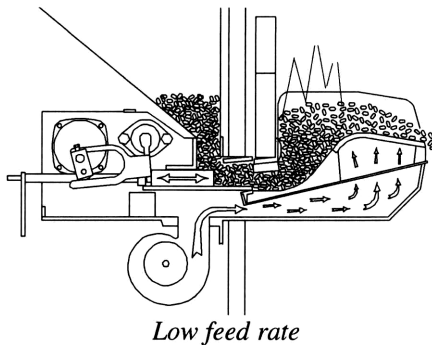

Over Fired, No Good

Maintenance

Ash Removal

With each hopper of coal that is burned, approximately one ash pan full of ashes must be removed. Failure to remove ashes will result in a blocked grate and the fire will not burn properly. Remember, the ash pan will be hot, so always wear protective gloves.

Ashes should be placed in a metal container with a tight fitting lid. The closed container of ashes should be placed on a non-combustible floor or on the ground, well away from all combustible materials, pending final disposal. If the ashes are disposed of by burial in soil, or otherwise locally dispersed, they should be retained in the closed container until all cinders have thoroughly cooled.

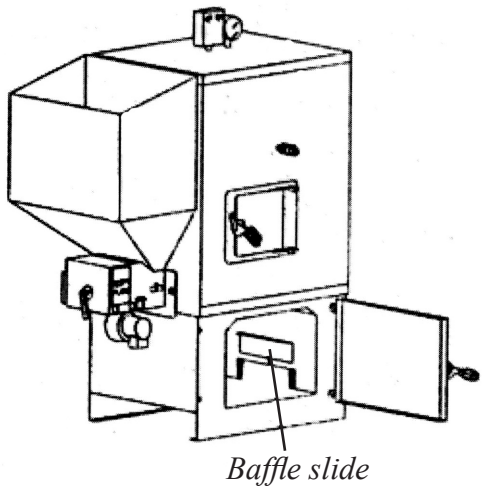
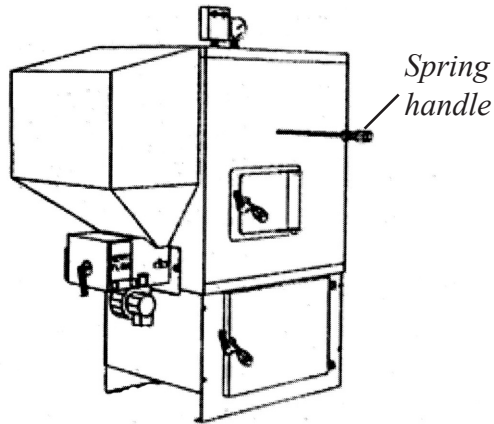

Weekly:

The small tray in the side of the stoker should be removed and emptied.

The spring handle located at the center of the unit should be cycled in and out several times. This action cleans the interior of the heat exchanger and causes the dust to fall into the ashpan.

Every 3 months:

The grate "clean-out" slide should be opened and reclosed as shown in drawings below.

In the "closed" position, be sure the "grate clean-out" plate slide is straight across as shown.

The easiest way to handle this slide is through the ash door with a poker inserted into the hole at the end. The purpose of this operation is to let any ash build-up, under the grate, fall into the ash tub.

This operation can be performed while the unit is burning. However, you should first lower the thermostat to lower the stove temperature and be sure you are wearing protective gloves.

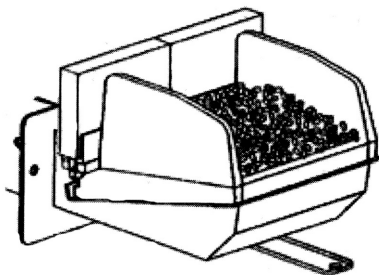

Slide open

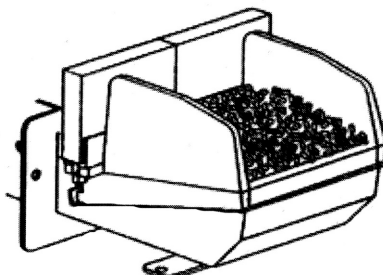

Slide closed

The operation can also be performed when the unit is not burning by lifting the grate inserts out and removing the ash with a vacuum cleaner.

Remove baffle slide as shown and remove fly ash.

Annually:

The end of the heating season is the best time to perform annual maintenance. Rust and corrosion can form much faster in the high humidity of summer, so cleaning your VF 3000 will prevent those damages.

1. Remove all coal from the hopper
2. Remove all ashes
3. Remove and clean flue pipe
4. Check chimney and clean if necessary
5. Remove hopper and check for rust at bottom edges. If rust is found, remove it with a file or sandpaper then paint the area with spray paint available at your Harman dealer.
6. Check the feeder for rust and corrosion where the hopper fits into it.
7. Check pusher block to be sure it moves freely. This can best be done by shaking the adjuster rod. If it does not move freely, it should be removed and cleaned. Also remove any rust or corrosion from the area where the pusher block slides and spray with WD-40 or other rust preventing spray. To remove pusher block, remove cover, wing nut, adjuster and adjuster tube. Remove motor mount with motor in place and cord still attached. Swing pusher assembly up as high as it will go. Remove feed indicator from side with allen wrench. Now the pusher block can be removed. To reinstall, just reverse procedure. If the pusher block cannot be removed, call your Harman dealer.

WARNING- Risk Of Fire;

- DO NOT Operate with flue draft exceeding -.10 in Water Column (-24.9 Pa.)
- DO NOT operate with fuel loading or ash removal doors open.
- DO NOT store fuel or other combustible material within specified installation clearance areas.
- INSPECT and clean chimney flue system and chimney connectors regularly.

Hopper Maintenance: Always empty the hopper when not burning for more than a week.

Pusher Block Maintenance: When left standing for long periods with wet coal, the pusher block will rust and corrode, causing it to stop. If the stoker is then turned "on", damage to the pusher assembly and feed motor will result. This will be considered neglect and will void the warranty on those parts. If the unit has not been burned for a period of time, always check to see if moving parts are free before using. This can best be determined by shaking the adjuster rod.

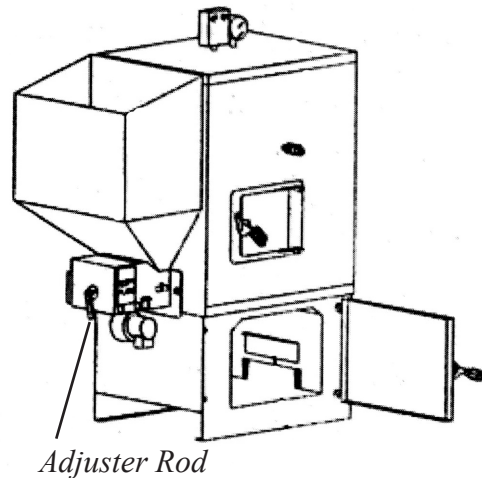

CAUTION:

- Inspect flue pipes, joints, and seals regularly to ensure that smoke and flue gases are not drawing into the dwelling.
- Cleaning of the heat exchanger, flue pipe, chimney, and draft inducer if used, is especially important at the end of the heating season to minimize corrosion during the summer months caused by accumulated ash.
- DO NOT use chemicals or fluids to start a fire.
- DO NOT burn garbage, gasoline, naphtha, engine oil, or other inappropriate materials.

Feeding Problems

Wet Coal: Wet coal does not flow the same as dry coal, therefore; the feed rate will change with wet coal. If it is too wet, it may not feed at all. Wet coal can also cause a sulfur odor.

Wrong Size Coal: The Verti-Flow™ System is designed to burn rice coal (or buckwheat coal if rice is not available). If buckwheat coal is burned, raise the draft setting from .04 to .06. Larger coal will not feed or burn properly.

Hopper Blocked: Sometimes wood, paper, or other foreign objects accidentally end up in your coal bin and can slow down or block the flow of coal. You may have to empty the hopper to find the blockage.

Pusher Out of Adjustment: This can happen when more than one person tend the stoker. One person does not tell the others what adjustments were made.

Gas Odor Problems

Gas Alarm Goes Off or Sulfur Odor Exists: A sulfur smell may be noticed when a door is opened during operation with wet or damp coal. This is normal. However, it is not recommended that wet coal be used or the doors be opened for more than a few seconds while burning to inspect the fire or remove ashes.

Lack of Draft or a Down Draft in the chimney: These will cause gases to escape from the unit. No unit will function properly without draft. Any draft problem should be corrected before use.

A draft inducer may be installed to increase draft in marginal situations. The installation should be performed by your dealer who is factory trained to correct any problems on initial start up. After proper installation, many years of trouble-free operation can be expected.

Stoker Control Troubleshooting

Problem: No motors or lights will turn on.

Solution:

1. Check AC power cord to the stoker control
2. Check the 3 amp fuse on the side panel of the stoker timer. (replace only with a 3 amp 3 ag slow blow fuse.)

Problem: Lights on the stoker control are on, but motors will not operate.

Solution: Check the AC power plugs from the motors (are they securely plugged into the correct outlet?)

Problem: One of the motors will not operate.

Solution: Check if the light above the receptacle is lit. Check the AC power plug from the motor (is it securely plugged into the correct outlet?)

Problem: The motors are cycling on and off, but not in the correct order.

Solution: Check the AC power plugs from the motors (are they securely plugged into the correct outlet?)

Problem: Coal feeder motor will not turn on.

Solution: Check if the red light is lit, if not, check if the feeder motor switch is turned on.

Problem: The motors turn on and off as programmed, but the water temperature is below the thermostat setting.

Solution: Check the connections from the stoker control to the aquastat.

AQUASTAT INSTALLATION (A350MY350, S350)

1. Lay the din rail on a flat surface with the flat side down. Secure one end clamp on the left side.
2. From the right side, slide the A350 control onto the din rail. Slide the control to the left until it is against the end clamp.
3. Repeat Step 2 with the Y350 power module, connecting it to the A350 control. NOTE: Be careful when fastening the plug-together connectors located at the top of the controls.
4. Repeat Step 3 with the S-350 control, connecting it to the Y350 power module.
5. Install the other end clamp to the right side of the din rail.
6. Remove the covers on the three controls by using the four screws on each control. (A350, Y350, S350)
7. Install the terminal box to the controls by using the three chase nipples and locknuts supplied with the kit.
8. Mount the terminal box with controls to the boiler jacket or any other desired location by the four holes in the terminal box.
9. Using two 8-32 nuts, install the terminal block over the studs located in the terminal box.
10. A350 Control: 1) Set the jumpers to the heat position. They may already be in this position. 2) Set the differential to the desired set point. 3) Terminate the wires using the common and the normally open terminals.
11. Y350 Control: 1) Terminate the power wiring using the 120 VAC terminals on the control. This will be supplied from the terminal block located in the terminal box.
12. S350 Control: 1) Set the offset to the desired set point. 2) Set the differential to the desired set point. 3) Set the jumpers to the cooling position. 4) Terminate the wiring using the common and the normally open terminals.
13. Set the A350 control to the desired water temperature.
14. After locating and installing the sensor well and sensor, wire the sensor to the A350 control. The terminals marked “sen” and “com” are located in the upper left-hand corner of the A350 control. Make sure the sensor is inserted into the well fully and secured with a setscrew.
15. Reinstall the covers on the three controls
16. NOTE: Sensor wire can be lengthened up to 50 feet with standard 22 awg t-stat wire. Shielded cable is generally not required for sensor wiring runs of less than 50 feet. However, if over 50 feet, follow this guide:

WIRE GAUGE/SHIELDED CABLE LENGTH

14 awg.....	800 feet
16 awg.....	500 feet
18 awg.....	310 feet
20 awg.....	200 feet
22 awg.....	124 feet

AQUASTAT

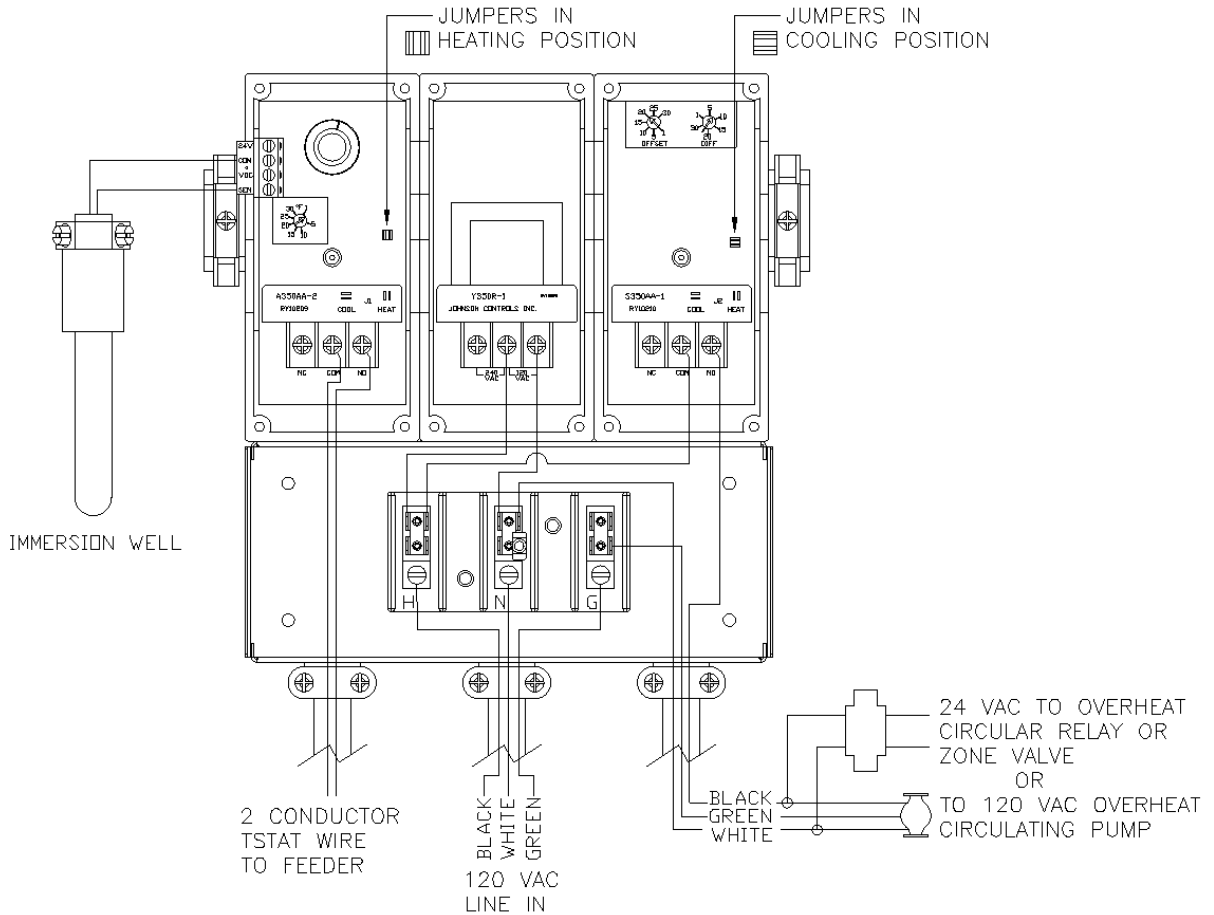
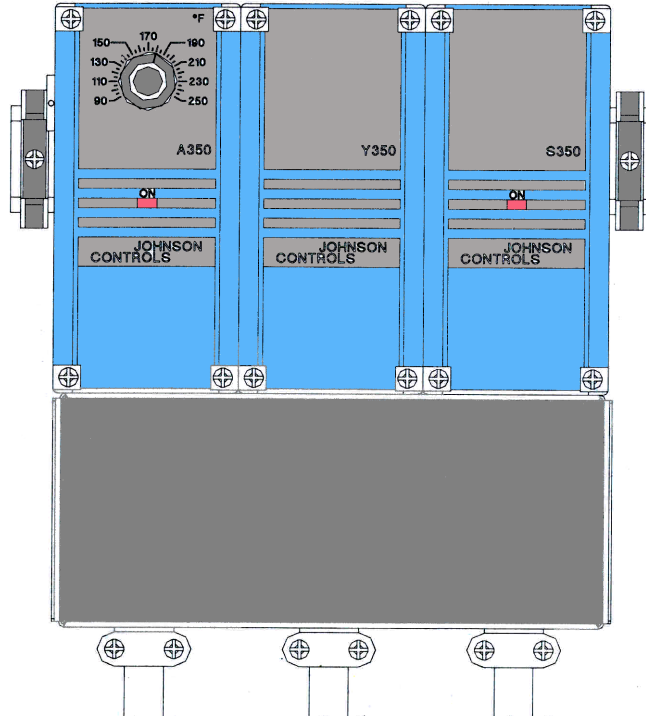

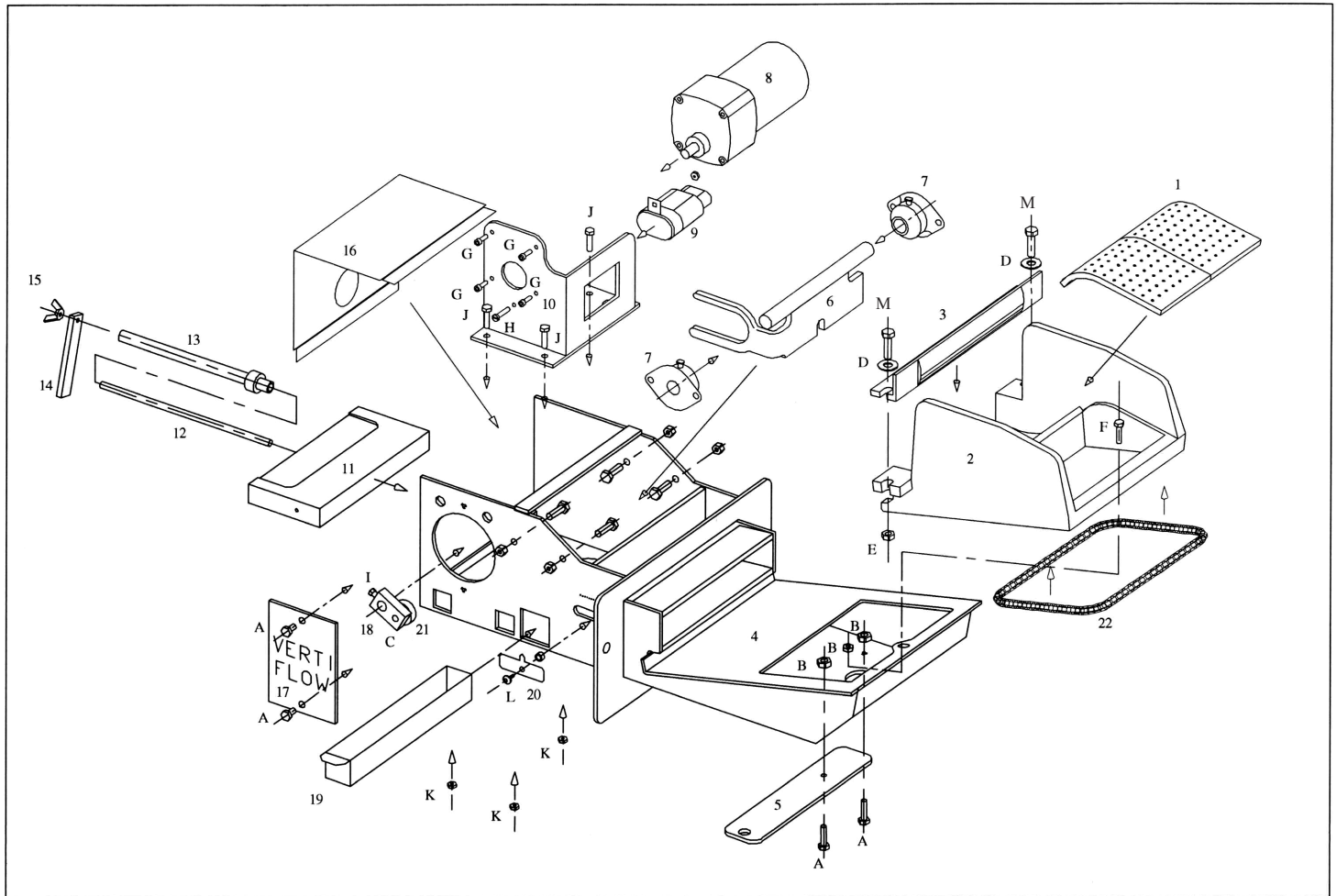

- 1. (2) grate inserts #4-00-00046
- 2. grate holder w/ angle #1-10-01000
- 3. grate angle #3-00-00218
- 4. feeder body #1-10-00687
- 5. clean-out slide #2-00-00048P
- 6. pusher arm #1-10-00025
- 7. (2) pillow block bearing #3-31-324122
- 8. feed motor #3-20-60075
- 9. capacitor #3-20-69654
- 10. motor mount #1-10-00031P
- 11. pusher block #3-50-00026
- 12. adjuster rod #2-00-08011
- 13. adjuster tube #1-10-00050P
- 14. adjuster #2-00-00051D
- 15. wing nut #3-30-8131181
- 16. motor cover #2-00-00052P
- 17. cam arm cover #2-00-00053P

- 18. cam arm #3-50-00054
- 19. dust tray #2-00-00055B
- 20. feed indicator #2-00-00056
- 21. cam bearing #3-31-3014
- 22. gasket #1-00-43375
- A. (4) 1/4 x 1/2 #3-30-1252005013
- B. (3) 1/4" nut #3-30-80252013
- C. 3/8 x 1 #3-30-3037161002
- D. (2) 3/8" washer #3-30-02003714
- E. (2) 3/8" nut #3-30-80371613
- F. 1/4" x 1 1/4" Allen #3-30-3025201502
- G. (4) 10-32 x 5/8" Allen #3-30-3010320622
- H. #10-32 screw and nut #3-30-608320501/8010321
- I. (1) 1/4" x 1/2" grade 8 #3-30-1252005014
- J. (3) 5/16" x 3/4" #3-30-1311807513
- K. (3) 5/16 nut #3-30-80311813
- L. (1) 1/4" x 5/8" button head #3-30-3125200622
- M. (2) 3/8 x 1-1/2" #3-30-1371615013

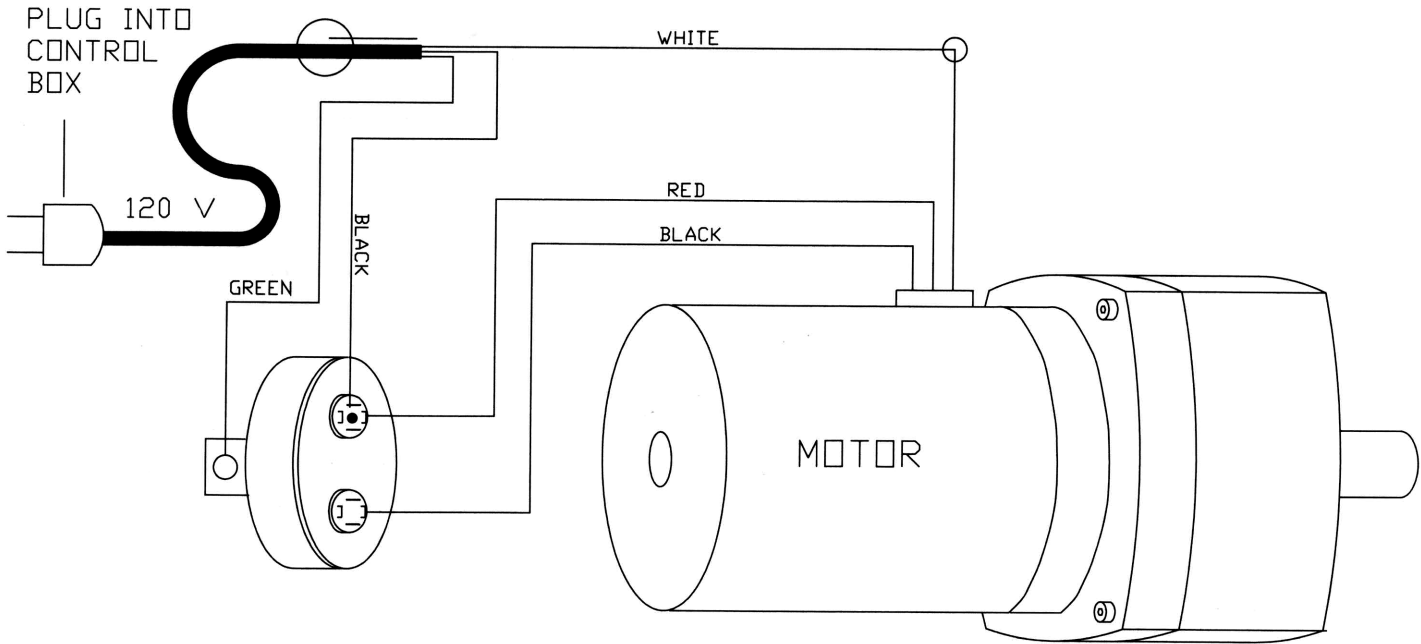

STOKER MOTOR WIRING DIAGRAM

Coal

Approved For Use With Anthracite Rice Coal Only.

Anthracite coal is “hard coal”, mined primarily in the northeast United States. Rice coal, as shown at right, is typically described as coal having no dimension larger than 3/8”. Other size coal may cause feeding problems, and is therefore not recommended for use in your VF3000.

It is best to buy your supply of coal when the temperature is above freezing. This is because many dealers put kerosene or fuel oil on the truck box and calcium on the coal to keep it from freezing while it is being transported. The calcium can promote rust and the oil may cause an odor depending on what type is used.

It is best and most convenient to have a coal bin inside and close to the boiler. The bin should have drainage to allow the water to drain.

DO NOT store fuel within the specified clearance area.

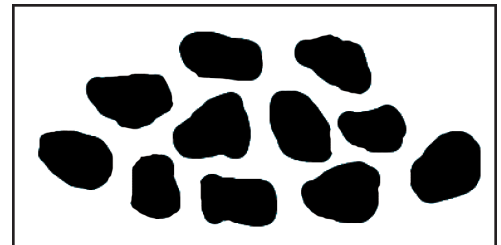

Rice Coal

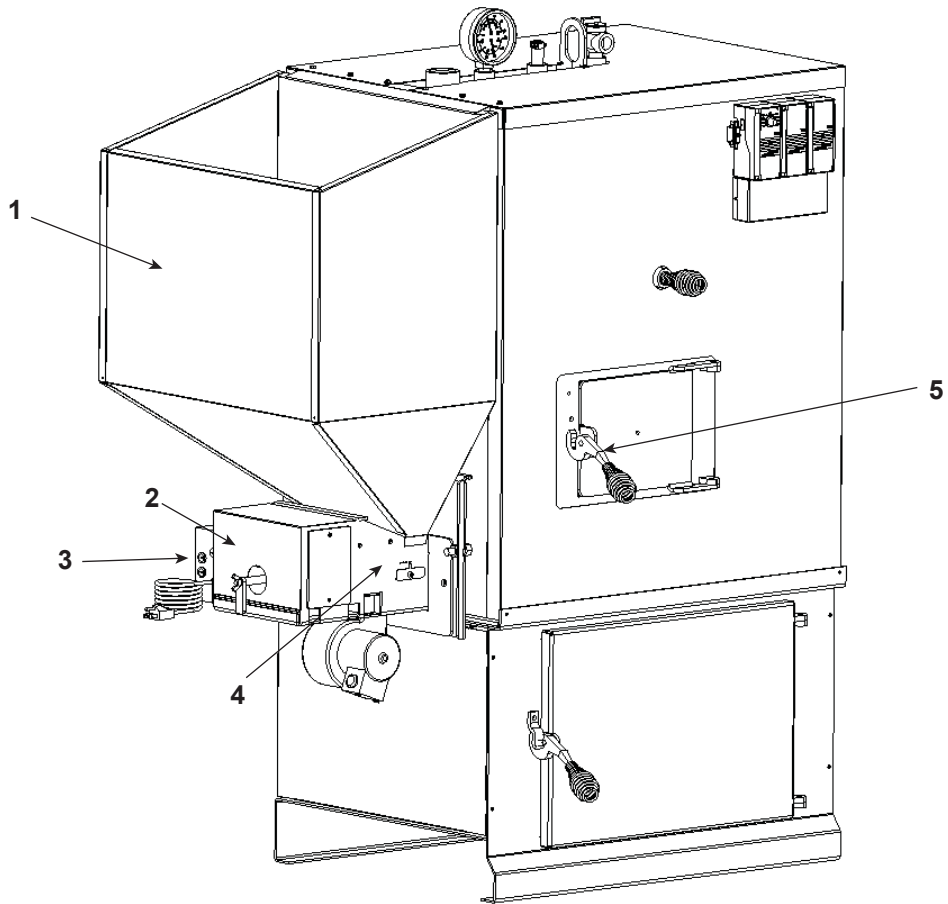

Part number list on following page.

IMPORTANT: THIS IS DATED INFORMATION. When requesting service or replacement parts for your appliance please provide model number and serial number. All parts listed in this manual may be ordered from an authorized dealer.



**Stocked
at Har-
man MFG**

ITEM	DESCRIPTION	COMMENTS	PART NUMBER	
1	Hopper assembly		1-00-4677373	
2	Verti-flow coal feeder assembly		1-00-00004	Y
3	Timer control box		3-20-44322	Y
4	Feeder body weldment		1-10-00687	Y
5	Door handle	Qty 2 req	4-00-00042	Y
	Aquastat replacement for White Rodgers		1-00-03500	Y
	Ash pan (galvanized tub - 12 gallon/#1) (available locally)		3-41-01882	
	Bearing 3/8 ID X 1-1/8 OD		3-31-3014	Y
	Blower 75cfm - 22 in cord		3-21-07522	Y
	Capacitor 370 Vac motor run		3-20-69654	Y
	Capacitor Holder Kit		3-20-36533	
	Cast grate insert (2 per)		4-00-00046D	Y
	Combustion blower restrictor plate		2-00-01023	
	Controller a350aa-2c		3-10-1350112	Y
	Door latch	Qty 2 req	2-00-00036	Y
	Feeder cam block		3-50-00054	Y
	Feeder cam block assembly		1-10-00102A	Y
	Feeder dust tray		2-00-00055	Y
	Fuse holder - (timer control box)		3-20-00900	Y
	Gasket 1/2" Rope (ash pan door)		1-00-53500	Y
	Gasket 1" w/adhesive - 1 ply (feeder gasket)		1-00-88100	Y
	Gasket 1" w/adhesive - 2 ply (fire door)		1-00-88250	Y
	Gearmotor-1/80hp - 4.5rpm		3-20-60075	Y
	Grate angle		3-00-00218	Y
	Grate holder assembly		1-10-01000	Y
	Oil burner optional		1-00-01050	
	Oil to coal on/off control assembly		1-10-01205A	Y
	Pillow block - 3/4" flange	Qty 2 req	3-31-324122	Y
	Power supply y350r-1c		3-10-935071	Y
	Pusher arm weldment		1-10-00025	Y
	Pusher block w/all thread		3-50-00026	Y
	Pusher block assembly w/tube		1-10-00099	Y
	Sensor/a350 control appbc-25c (aquastat well sensor)		3-10-2992225	Y
	Spring handle - brass plate 1/2"	Qty 3 req	3-40-00086-3	
	Stage module s350aa-1c		3-10-7350111	Y
	Thermostat-low voltage		3-20-12080	
	Well wel11a-601r		3-10-935111	Y

HARMAN™ CENTRAL HEATING PRODUCTS LIMITED WARRANTY

Hearth & Home Technologies Inc., on behalf of its Harman™ brand ("HHT"), extends the following warranty for all Harman™ furnace and boiler products ("Products") that are purchased from an HHT authorized dealer.

Warranty Coverage: Subject to the conditions, exclusions and limitations set forth below, HHT warrants to the original owner of the Products, and to any transferee taking ownership of the Products at the site of original installation within two years following the date of original purchase, that the Products will operate free from defects in material and workmanship under normal conditions and use, as described in the operating instructions furnished with the Product, during the warranty period described below. HHT will, at its option, repair or replace any Product covered by this warranty that is determined to be defective in material or workmanship.

Warranty Period: The warranty period runs for six years, except for mechanical and electrical components, which are warranted for three years. The warranty period begins on the earlier of: (i) the date of invoice for the Product; (ii) in the case of new home construction, the date of first occupancy of the residence or six months after the date of sale of the Product by an HHT authorized dealer, whichever occurs first; or (iii) the date 24 months following the date of Product shipment from HHT, regardless of the invoice or occupancy date.

Warranty Conditions: This warranty applies only to Products: (i) installed, operated, and maintained as recommended in the Product user's manual; (ii) purchased through an HHT authorized dealer; (iii) while remaining at the site of original installation; and (iv) that have not been altered after leaving the factory.

How to File a Claim: Claims must be made within the warranty period to the dealer who sold the Product. If that dealer cannot provide the warranty service, contact the nearest HHT authorized dealer. Additional service fees may apply if you are seeking warranty service from a dealer other than the dealer from whom you originally purchased the Product. Travel and shipping charges for parts are not covered by this warranty.

Warranty Exclusions: This warranty does not cover the following: (1) consumable and normal wear items, including, without limitation, flame guides, grates, coal bars, afterburner hoods, fire brick, gaskets, paint, glass discoloration, burnpot housing weldments, burnpot grate weldments (pellet or corn), burnpot front plates (pellet or corn), burnpot front plate locks, corn auger extensions, ceramic inserts, and ceramic insert plates; (2) noise caused by minor expansion, contraction or movement of parts; (3) damage resulting from: (i) failure to install, operate or maintain the Product according to the installation and operating instructions and listing agent identification label furnished with the Product; (ii) failure to install the Product according to local building codes; (iii) shipping or improper handling; (iv) abuse, misuse, continued operation with damaged, corroded or failed components, accident, or incorrectly performed repairs; (v) environmental conditions, inadequate ventilation, negative pressure or drafting caused by tightly sealed construction, insufficient make-up air supply, or handling devices such as exhaust fans or forced air furnaces or other such causes; (vi) use of fuels other than those specified in the operating instructions; (vii) installation or use of components or accessories not supplied with the Product or authorized and approved in writing by HHT; (viii) modification of the product not expressly authorized and approved by HHT in writing; or (ix) interruptions or fluctuations of electrical power supply to the Product; (4) non-HHT components or accessories used in conjunction with the Product; (5) the Products' capability to heat a desired space; information is provided to assist the consumer and the dealer in selecting the proper Product for the application; consideration must be given to Product location and configuration, environmental conditions, insulation and air tightness of the structure; or (6) additional or unusual utility bills incurred due to any malfunction or defect in Products.

Limitations of Liability: Repair or replacement in accordance with the provisions of this warranty will be the owner's exclusive remedy for and will constitute HHT's sole obligation under this warranty, under any other warranty (express or implied), or in contract, tort or otherwise. No employee, agent, dealer, or other person is authorized to give any warranty on behalf of HHT. TO THE EXTENT ALLOWED BY LAW, HHT MAKES NO OTHER WARRANTY, EXPRESS OR IMPLIED, INCLUDING ANY WARRANTY OF MERCHANTABILITY OR FITNESS FOR A PARTICULAR PURPOSE. HHT WILL NOT BE LIABLE FOR ANY CONSEQUENTIAL OR INCIDENTAL DAMAGES ARISING OUT OF DEFECTS IN OR USE OF THE PRODUCTS. Some states do not allow exclusions or limitation of incidental or consequential damages, so these limitations may not apply to you. This warranty gives you specific rights; you also may have other rights, which vary from state to state. The duration of any implied warranty is limited to the duration of the warranty period specified herein.

